

# STORINGSLIJST HI-THERMA

Error Code

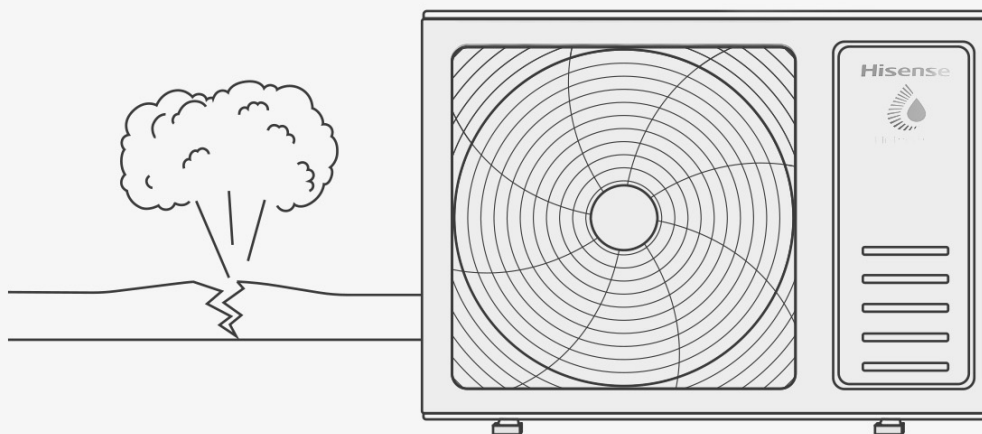

De Hi-Therma storingslijst een essentieel hulpmiddel voor installateurs om snel en effectief problemen op te lossen met de Hisense lucht/water warmtepomp. Onze toewijding aan betrouwbare en efficiënte verwarmingssystemen wordt weerspiegeld in de geavanceerde technologie van de Hi-Therma. Deze storingslijst is ontworpen om installateurs te voorzien van gedetailleerde informatie en richtlijnen, waardoor zij snel en doeltreffend storingen kunnen identificeren en oplossen.

De Hi-Therma warmtepomp van Hisense vertegenwoordigt de nieuwste innovaties op het gebied van duurzame verwarmingstechnologie. Om ervoor te zorgen dat uw installatie optimaal presteert, hebben we deze storingslijst samengesteld als een waardevol naslagwerk. Hier vindt u een uitgebreide lijst met mogelijke storingen, vergezeld van gedetailleerde instructies en oplossingen.

Om uw efficiëntie bij het oplossen van storingen te maximaliseren, hebben we een eenvoudig en doeltreffend systeem geïntegreerd in onze Hi-Therma Storingslijst. Als u geconfronteerd wordt met een storing, heeft de Hi-Therma warmtepomp een specifieke alarmcode die op de unit wordt weergegeven. Hier is hoe u snel en nauwkeurig toegang krijgt tot de benodigde informatie:

**1. Alarmcode identificeren:**

Wanneer zich een storing voordoet, observeert u de alarmcode die op het display van de Hi-Therma unit verschijnt. Deze code is essentieel voor een snelle diagnose.

**2. Stapsgewijze oplossingen in de Storingslijst:**

Op onze storingslijst hebben we elke mogelijke storing georganiseerd op basis van de bijbehorende alarmcodes. Op de eerste pagina van de storingslijst vindt u een overzicht van alarmcodes.

**3. Directe toegang tot oplossingen:**

Klik eenvoudigweg op de alarmcode die overeenkomt met de storing op de unit. Deze klik leidt u onmiddellijk naar de juiste pagina in het document met gedetailleerde instructies en oplossingen voor de specifieke storing.

**1.2.3 Troubleshooting by Alarm Code**

Alarm Code	Category	Cause Code of Stoppage	Detail of Abnormality	Main Factors
02	Outdoor unit	d1-13	Activation of Protection Device (High Pressure Switch)	Activation of PSH (Pipe Clogging, Excessive Refrigerant, Inert Gas Mixing)
03	Outdoor/Indoor unit	d1-05/d1-06	Abnormal transmission between the indoor unit and the outdoor unit	Incorrect Wiring, Loose Terminals, Disconnect Wire, Blowout of Fuse, Outdoor or Indoor Unit Power OFF
04	Outdoor unit	d1-05	Abnormal Transmitting between Outdoor Unit main PCB and Inverter	O.U. main PCB and Inverter Transmission Failure (Loose Connector, Wire Breaking, Blowout of Fuse)
06	Outdoor unit	d1-18	Abnormal Inverter Voltage	Outdoor Voltage Drop, Insufficient Power Capacity
07	Outdoor unit	d1-16	Decrease in Discharge Gas Superheat	Excessive Refrigerant Charge, Failure of Thermistor, Incorrect Wiring, Incorrect Piping Connection, Expansion Valve Locking at Opened Position (Disconnect Connector)
08	Outdoor unit	d1-15	Increase in Discharge Gas Temperature	Insufficient Refrigerant Charge, Pipe Clogging Failure of Thermistor, Incorrect Wiring, Incorrect Piping Connection, Expansion Valve Locking at Closed Position (Disconnect Connector)
11	Indoor unit	d1-02	Inlet Water Thermistor(Tiw) Abnormality	Incorrect Wiring, Disconnecting Wiring Breaking Wire, Short Circuit
12	Indoor unit	d1-02	Outlet Water Thermistor(Tow) Abnormality	Incorrect Wiring, Disconnecting Wiring Breaking Wire, Short Circuit
13	Indoor unit	d1-02	Liquid Refrigerant Pipe Thermistor(TL) Abnormality	Incorrect Wiring, Disconnecting Wiring Breaking Wire, Short Circuit
14	Indoor unit	d1-02	Gas Refrigerant Pipe Thermistor(Tg) Abnormality	Incorrect Wiring, Disconnecting Wiring Breaking Wire, Short Circuit
16	Indoor unit	d1-02	DHW Thermistor(TDHW) Abnormality	Incorrect Wiring, Disconnecting Wiring Breaking Wire, Short Circuit
17	Indoor unit	d1-02	Outlet HP Water Thermistor(TowHP) Abnormality	Incorrect Wiring, Disconnecting Wiring Breaking Wire, Short Circuit
18	Indoor unit	d1-02	Water Pressure Sensor(Pw) Abnormality	Incorrect Wiring, Disconnecting Wiring Breaking Wire, Short Circuit
22	Outdoor unit	-	Outdoor Unit Ambient Thermistor(Ta)	Incorrect Wiring, Disconnecting Wiring Breaking Wire, Short Circuit
23	Outdoor unit	-	Compressor Discharge Gas Thermistor (Td)	Incorrect Wiring, Disconnecting Wiring Breaking Wire, Short Circuit
24	Outdoor unit	-	Heat Exchanger Liquid Pipe Thermistor (Te)	Incorrect Wiring, Disconnecting Wiring Breaking Wire, Short Circuit
25	Outdoor unit	-	Heat Exchanger Liquid Pipe Thermistor 2 (Te2)	Incorrect Wiring, Disconnecting Wiring Breaking Wire, Short Circuit
31	Outdoor unit	-	Incorrect Capacity Setting of Outdoor Unit and Indoor Unit	Incorrect Capacity Setting of Outdoor Unit and Indoor Unit
35	Outdoor unit	-	Incorrect Setting of Indoor Unit No.	Incorrect Setting of Indoor Unit No.
43	Outdoor unit	d1-11	Activation of Low Compression Ratio Protection Device	Defective Compression (Failure of Compressor or Inverter, Loose Power Supply Connection)
47	Outdoor unit	d1-15	Activation of Low Pressure Decrease Protection Device (Vacuum Operation Protection)	Insufficient Refrigerant, Refrigerant Piping, Clogging, Expansion Valve Locking at close Position (Loose Connector)
48	Outdoor unit	d1-17	Activation of Inverter Overcurrent Protection Device	Overload Operation, Compressor Failure
51	Outdoor unit	d1-17	Abnormal Inverter Current Sensor	Current Sensor Failure
53	Outdoor unit	d1-17	Inverter Error Signal Detection	Error Signal Detection (IPM Error, Step-Out Detection, PFC hardware Error)
54	Outdoor unit	d1-17	Abnormality of Inverter Fin Temperature	Abnormal Inverter Fin Thermistor, Inverter fin thermistor protection activation
55	Outdoor unit	d1-18	Inverter Failure	O.U. main PCB Failure
57	Outdoor unit	d1-18	Activation of Fan Controller Protection	Abnormal speed of Fan-motor

Alarm Code	Category	Cause Code of Stoppage	Detail of Abnormality	Main Factors
70	Indoor unit	d1-70	Water Pressure Alarm	Water pressure is detected abnormality in the hydraulic cycle
71	Indoor unit	d1-02	Protection Thermostat of DHW Electric Heater Activation	High temperature is detected in DHW Electric Heater
72	Indoor unit	d1-02	Protection Thermostat of Auxiliary Electric Heater Activation	High temperature is detected in Auxiliary Electric Heater
74	Indoor unit	d1-74	Overheating protection for water Cycle 2	Water Cycle 2 supply temperature > Target temperature + offset lasting for 10mins.
75	Indoor unit	d1-75	Water Pump (WP1) malfunction	Water Pump (WP1) output iPWM is detected abnormality
76	Indoor unit	d1-31	Freeze Protection Stop by indoor unit temperature thermistors	Water temperature or refrigerant temperature is too low and trigger freezing protection
78	Indoor unit	d1-78	Hydraulic flow abnormality alarm (WP1)	Water flow is detected abnormality in the hydraulic cycle
80	Indoor unit	d1-02	Transmission failure between unit and Master Controller	No Transmission for a continuous period of 5 minutes between Unit and Master Controller. failed wiring (breaking, wiring error, etc.)
-	Indoor unit	d1-03	Freeze protection	Space Cooling is on and Outlet HP Water Thermistor(TowHP) $\leq 3^{\circ}\text{C}$ lasting for 100s or Inlet Water Thermistor(Tiw) $\leq 5^{\circ}\text{C}$ lasting for 100s.
-	Indoor unit	d1-07	Stoppage of Cooling Operation due to Low Outdoor Air Temperature	Space Cooling is on and Outdoor Ambient Temperature in 30mins or Second Outdoor Ambient Temperature in 30mins is equal or lower to $5^{\circ}\text{C}$ .
A1	Indoor unit	d1-02	Auxiliary sensor Abnormality (Tow3)	Loose, disconnected, broken or short-circuited connector. Or the condition of Hydraulic Separator is Enabled but Tow3 has not been set in all the Auxiliary sensors (A1-A7).
A2	Indoor unit	d1-02	Auxiliary sensor Abnormality (Tswp)	Loose, disconnected, broken or short-circuited connector. Or the condition of Swimming pool is Enabled but Tow2 has not been set in all the Auxiliary sensors (A1-A7).
A3	Indoor unit	d1-02	Auxiliary sensor Abnormality (Tsolar)	Loose, disconnected, broken or short-circuited connector. Or the condition of Solar function need to be set as the solar sensor but Tsolar has not been set in all the Auxiliary sensors (A1-A7).
A4	Indoor unit	d1-02	Auxiliary sensor Abnormality (Tow2)	Loose, disconnected, broken or short-circuited connector. Or the condition of Cycle 2 is Enabled but Tow2 has not been set in all the Auxiliary sensors (A1-A7).
A5	Indoor unit	d1-02	Auxiliary sensor Abnormality (Room_amb1...7)	Loose, disconnected, broken or short-circuited connector.
F1	Indoor unit	d1-02	Alarm sent by Outdoor unit (Outdoor unit alarm 21-29)	-
F2	Indoor unit	d1-02	Alarm sent by Outdoor unit (Outdoor unit alarm except 21-29 and EE)	-
F3	Indoor unit	d1-02	Alarm sent by Outdoor unit (Outdoor unit alarm EE)	-
H2	Wired Remote Controller and Master Controller	-	Wired Remote Controller and Master Controller transmission alarm	Wired Remote Controller is configured as room thermostat but no Wired Remote Controller is detected.
EE	Outdoor unit	-	Compressor Protection Alarm (It can not be reset from Master Controller)	This alarm code appears when the following alarms* occurs three times within 6 hours. *02, 07, 08, 43 to 45, 47

1.2.3.1 Troubleshooting by Alarm Code (O.U.)

Alarm Code	02	Activation of the safety device (high pressure switch) in the outdoor unit
------------	----	--

Alarm code is displayed on the master controller/ the 7-segment of O.U. display PCB / the 7-segment of I.U. PCB1.

★ PSH is activated 6 times in one hour the alarm occurs.

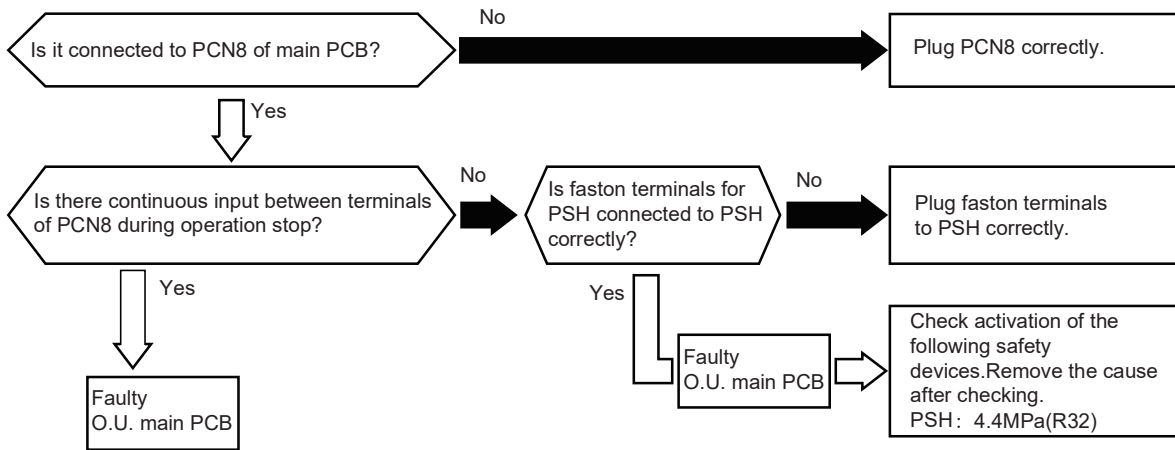

Phenomenon	Cause	Check item	Action (Turn OFF Main Switch)	
Activation of the high-pressure switch due to the excessively high discharge pressure (PSH)	Outdoor Unit: Insufficient Air Flow to the Heat Exchanger (Outdoor Heat Exchanger during the Cooling Process) Indoor Unit: Insufficient Water Flow to the Heat Exchanger Indoor Heat Exchanger (during the Heating Process)	Check the heat exchanger for dust or for clogging	Remove the dust or the clogging	
		Check the air filter for dust	Remove the dust	
		Check for any obstacles at the inlet or the outlet of the heat exchanger	Remove the obstacles	
		Check the service area	Secure service area	
		Check the speed (Outdoor Fan: Cooling)	Replace the fan motor if faulty	
		Check the speed of the water pump	Replace the water pump if faulty	
	Expansion valve malfunction or abnormality	Disconnected	Fix the looseness or reconnect the connector	
		Fully closed and locked	Replace the expansion valve	
		Check the operation sound of the coil	Replace the coil	
		Check the Discharge Gas thermistor	Replace the thermistor	
		Check the fastening of the thermistor	Re-fasten the thermistor	
	Excessively High Water Temperature in the indoor unit	Calculate the heat load	Reduce the heat load or use a bigger unit	
		Check minimum water flow	Provide good circulation	
		Check for collapse in water cycle	Remove the short-circuited	
		Check for other heat source	Stop the heat source	
	Faulty High-Pressure Switch	Faulty Pressure Switch	Measure the discharge pressure. Check the continuity after the decrease of the pressure	Replace the pressure switch if faulty
		Insufficient Contacting	Measure the resistance by means of a tester	Fix the looseness. Replace the connector
		Incorrect Connection	Check the connections	Repair the connections
	Overcharged refrigerant		Check the cycle operation temp.	Charge the refrigerant correctly
	Mixture of the non-condensate gas in the refrigerant cycle		Check the air temp. and the pressure	Recharge the refrigerant after the vacuum pumping
Clogging of the discharge piping		Check for clogging	Remove the clogging	
Liquid line stop valve or gas line stop valve is not in operation		Check the stop valves	Fully Open the stop valves	

Alarm Code	03	Abnormal Transmitting between Indoor and Outdoor Units
------------	----	--

Alarm code is displayed on the master controller/ the 7-segment of O.U. display PCB / the 7-segment of I.U. PCB1.

- ★ This alarm is displayed when abnormal transmission between O.U. and I.U. is maintained for three minutes after the normal transmission. Also, abnormal transmission between O.U. and I.U. is maintained for 30 seconds after the micro-computer is automatically reset.
- ★ The alarm is displayed when the abnormal transmission is maintained for 30 seconds from the starting of the outdoor unit.
- ★ Investigate the cause of the overcurrent and take the necessary action when the fuses are blown out or the breaker for the outdoor unit is activated.

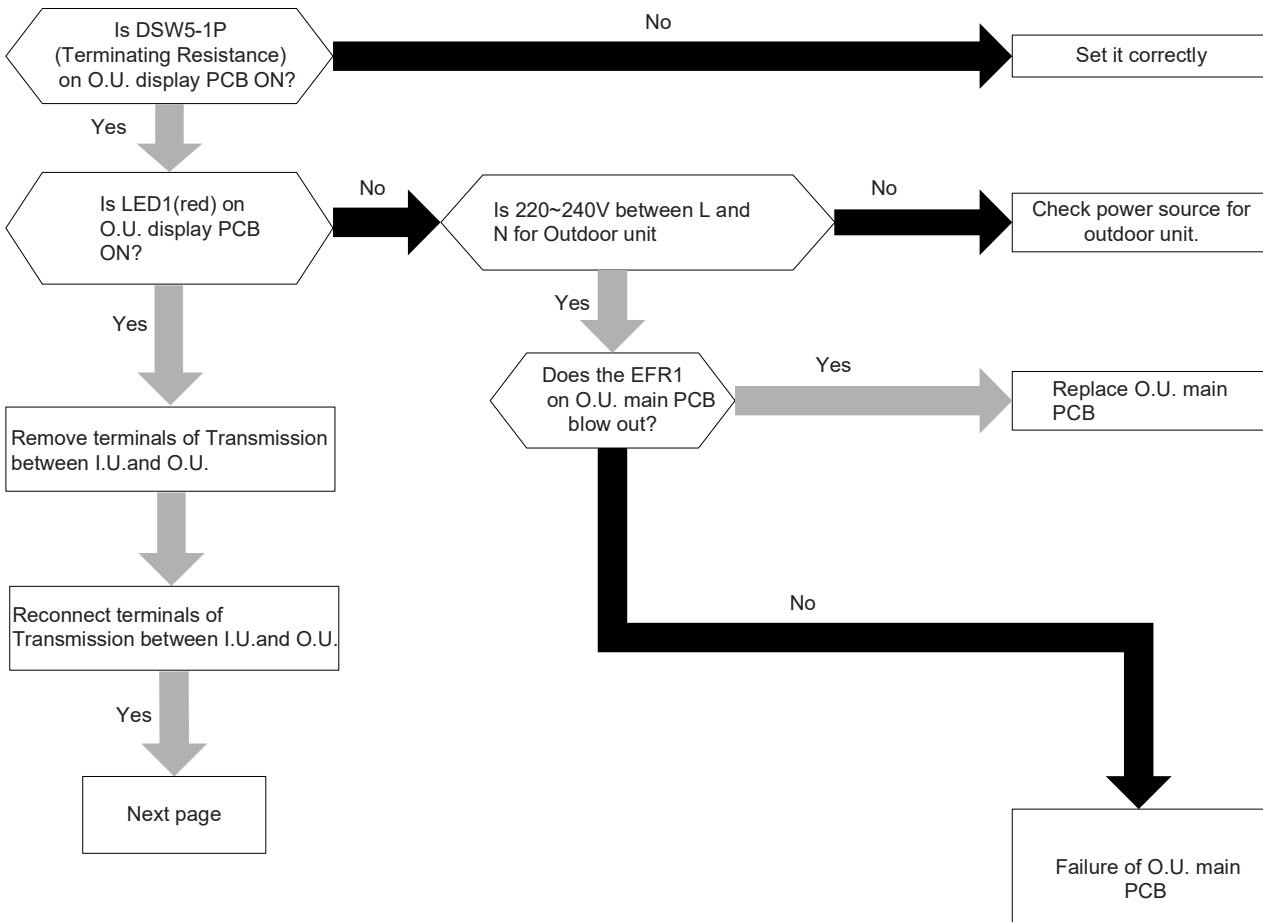

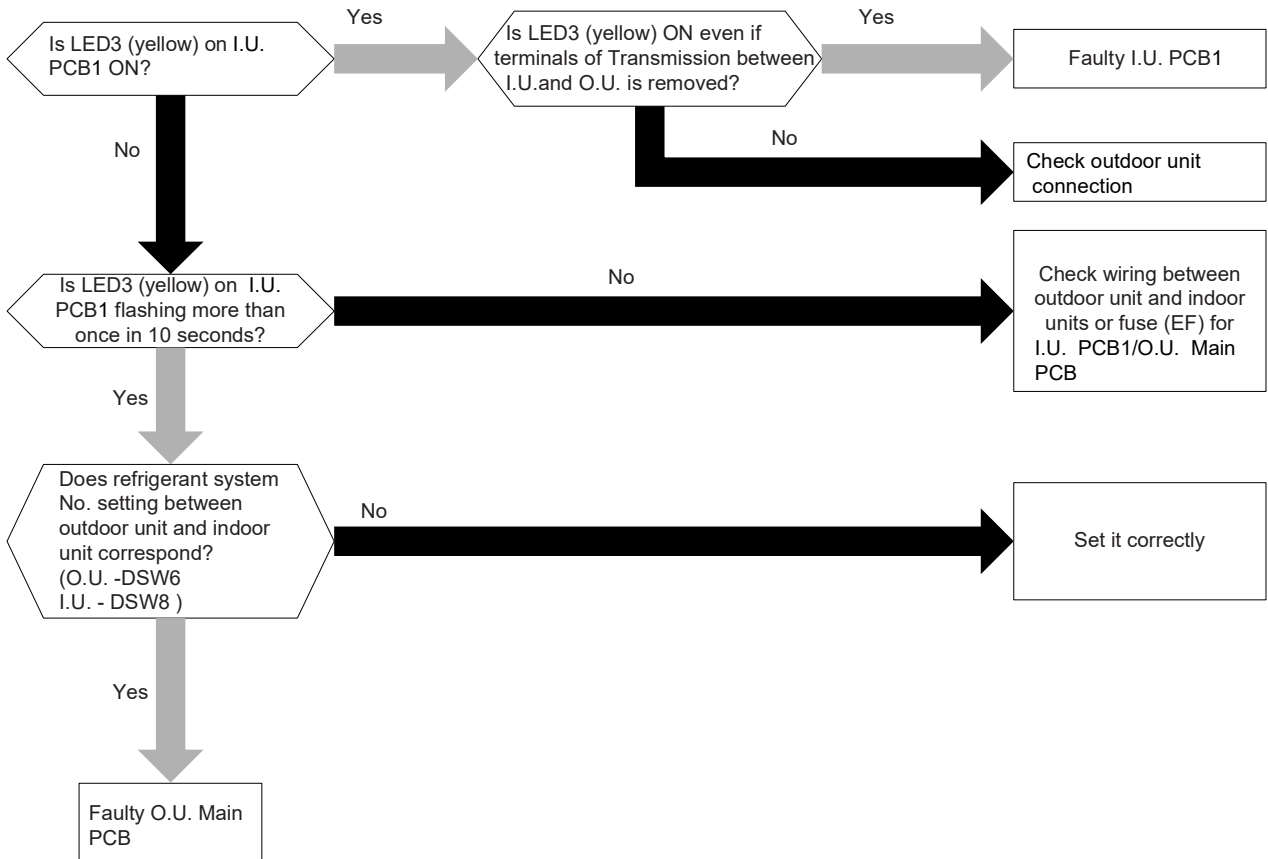



Phenomenon	Cause	Check item	Action (Turn OFF Main Switch)
Power failure or power is not ON		Measure the voltage by tester.	Supply power.
Melted Fuse for Power Supply or Activation of Breaker (Outdoor Unit )	Short Circuit between Wires	Check for breakage of insulation.	Remove cause of short circuit. Replace fuse on I.U. PCB1 or O.U.main PCB if faulty.
	Short Circuited Wire to Ground	Measure insulation resistance.	Remove cause of short circuit. Replace fuse on I.U. PCB1 or O.U.main PCB if faulty.
	Faulty Comp. Motor	Measure resistance between wires and insulation resistance.	Replace O.U. main PCB.
	Faulty Outdoor Unit Fan Motor	Measure resistance between wires and insulation resistance.	Replace outdoor unit fan motor and fuse. Replace O.U. PCB if faulty.
Melted Fuse on PCB (Outdoor Unit)	Short Circuit between Wires	Check for breakage of insulation.	Remove cause of short circuit.
	Short Circuit (to Ground)	Measure insulation resistance.	Remove cause of short circuit .
	Faulty Electrical Coil Resistance for Comp. Motor	Measure resistance of coil.	Replace Compressor wiring or Compressor refer to 1.3.4.
	Failure of Outdoor Unit Fan Motor	Measure resistance between wires and insulation resistance.	Replace fan motor refer to 1.3.4.
Incorrect Power Supply	Circuit of O.U. main PCB	Measure O.U. main PCB output.	Replace electrical box
Disconnected Wires Insufficient Contacting or Incorrect Connection	Between Outdoor Unit and Indoor Unit	Check continuity of wires.	Replacing wires, repairing and tightening screws.
	Power Supply Wiring for Outdoor Unit	Check for looseness of connection screws. Check terminal Nos.	Correctly connect wires.
Faulty PCB(Outdoor Unit,Indoor Unit)	Disconnected Wires to Check connection I.U.PCB1/O.U. main PCB	Check connections.	Correctly connect wires.
	Faulty I.U.PCB1/O.U. main PCB		Replace it if faulty.
Incorrect Wiring	Disconnected Wire Insufficient Contacting	Check continuity and looseness of connection screws.	Replacing Wires, Repairing and Tightening Screws
	Incorrect Wiring	Check terminal	Correctly connect wires.

Alarm Code 04	Abnormal Transmitting between Outdoor Unit main PCB and Inverter
---------------	--

- Alarm code is displayed on the master controller/ the 7-segment of O.U. display PCB / the 7-segment of I.U. PCB1.
- ★ This alarm code is indicated when abnormality continues for 30 seconds after normal transmitting between the outdoor unit PCB and Inverter, and also abnormality continues for 30 seconds after the microcomputer is automatically reset. The alarm is indicated when the abnormal transmitting continues for 30 seconds from starting of the outdoor unit.

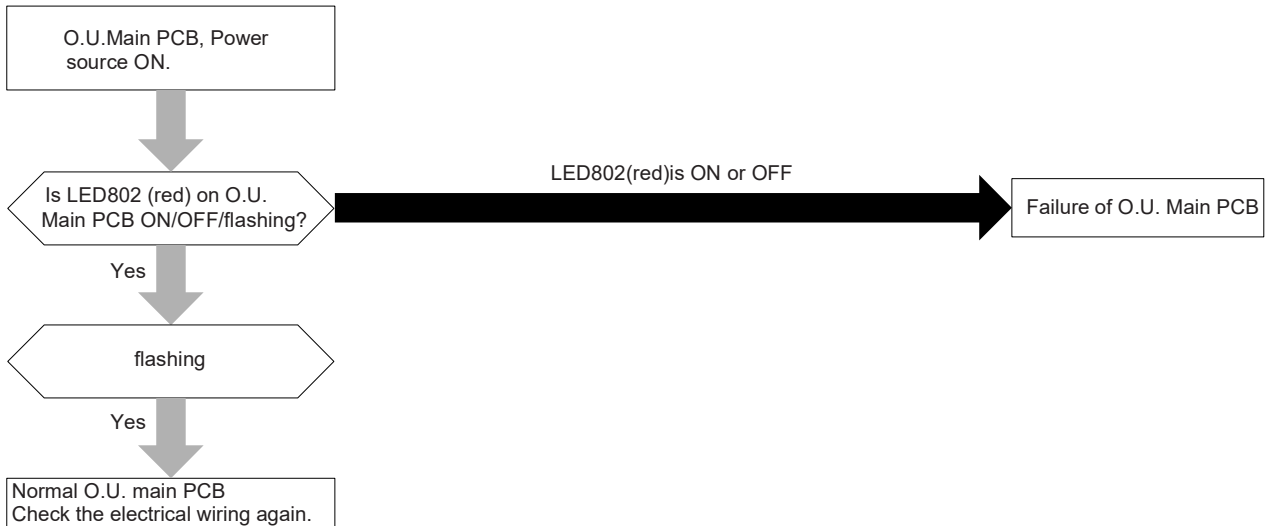

Phenomenon	Cause	Check Item	Action(Turn OFF Main Switch)
Disconnected Wires, Insufficient Contacting or Incorrect Connection	Power Supply Wiring for Outdoor Unit	Check continuity of wires. Check for looseness of connection screws. Check connection No.	Replacing wires, repairing, tightening screws and incorrect wiring.
Faulty O.U. main PCB	Disconnected Wires to O.U. main PCB	Check connections.	Repair wiring connections.
	Faulty O.U. main PCB		Replace electrical box if faulty.
Faulty Electrical Components Power Fuse, Resistance	Melted Power Fuse	Check conductivity of power fuse, power transistor, diode module.	Replace power fuse and power transistor,
	Disconnected Incoming Current Limit Resistance	Check resistance of incoming current limit resistance.	Replace incoming current limit resistance.
Incorrect Wiring	Disconnected Wire Insufficient Contacting	Check continuity and looseness of connection screws.	Replacing Wires, Repairing and Tightening Screws
	Incorrect Wiring	Check terminal Nos.	Correctly connect wires.

Alarm Code	06	Abnormal Inverter Voltage (Insufficient Inverter Voltage or Overvoltage)
------------	----	---

- Alarm code is displayed on the master controller/ the 7-segment of O.U. display PCB / the 7-segment of I.U. PCB1.
- ★ When either insufficient voltage or overvoltage is detected on the inverter three times in 30 minutes, the operation stops and this alarm code is displayed. If this occurs less than three times in 30 minutes, the operation is automatically retried.

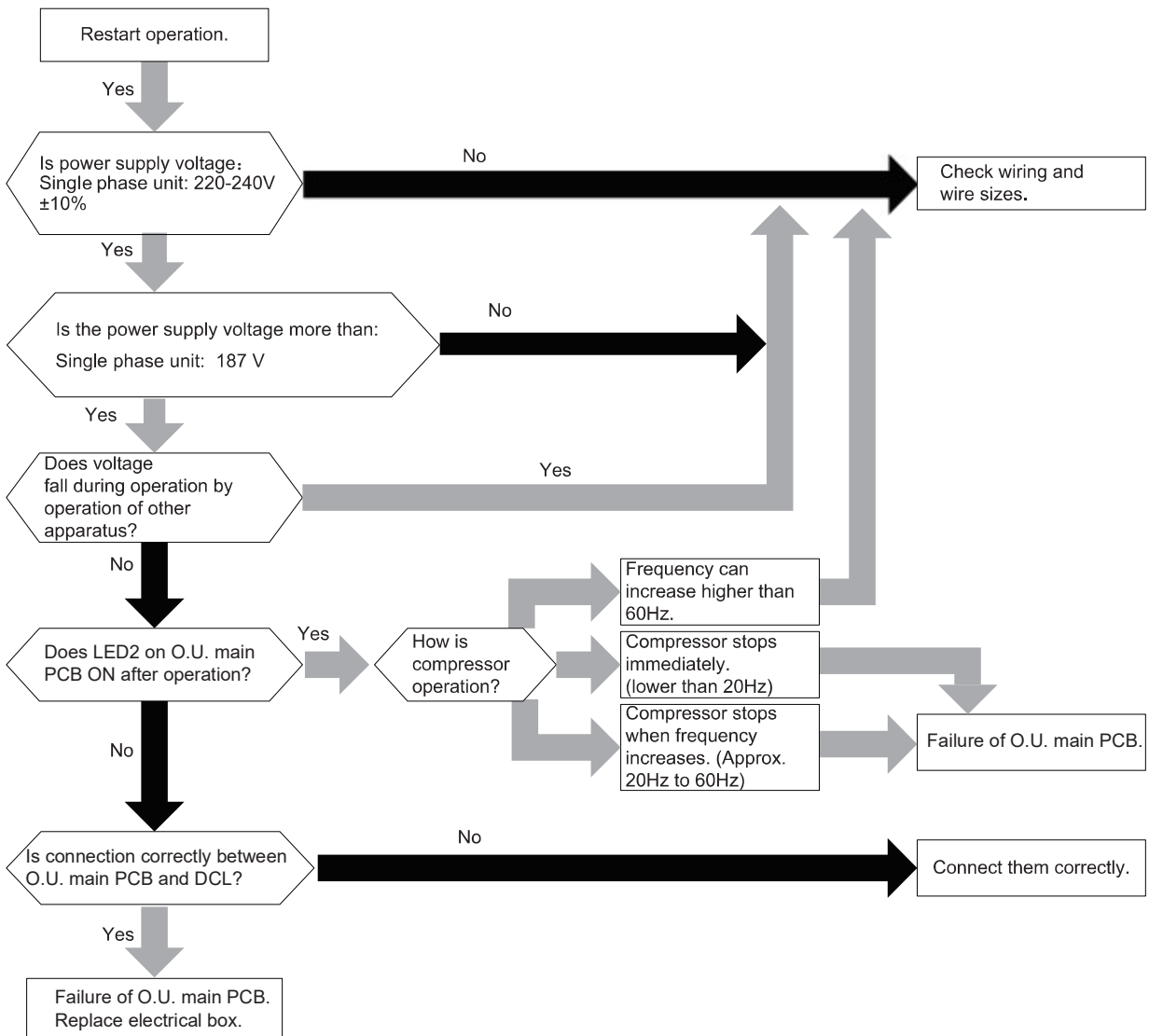

Alarm Code <b>07</b>	<b>Decrease in Discharge Gas Superheat</b>
----------------------	--

- Alarm code is displayed on the master controller/ the 7-segment of O.U. display PCB / the 7-segment of I.U. PCB1.
- ★ If the temperature of compressor discharge gas (Td) is below the estimated condensing temperature for 30 minutes during operation, the compressor stops and then the operation is automatically retried after three minutes. If this occurs again twice in the next 120 minutes, this alarm code is displayed.
- ★ This alarm code is displayed when an abnormality cannot be detected by the step-out detection, caused by locking of compressor shaft.

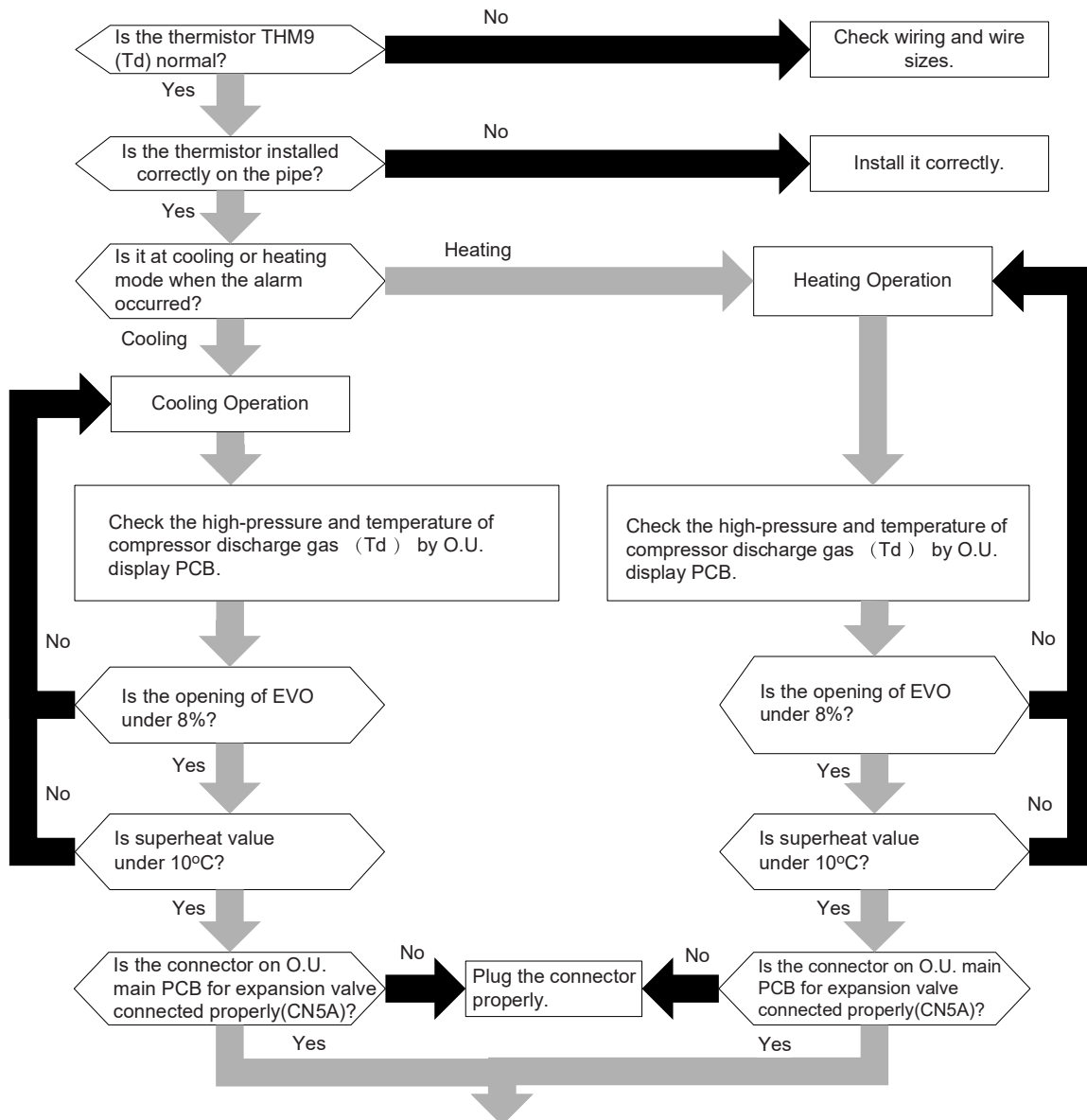

The next page.

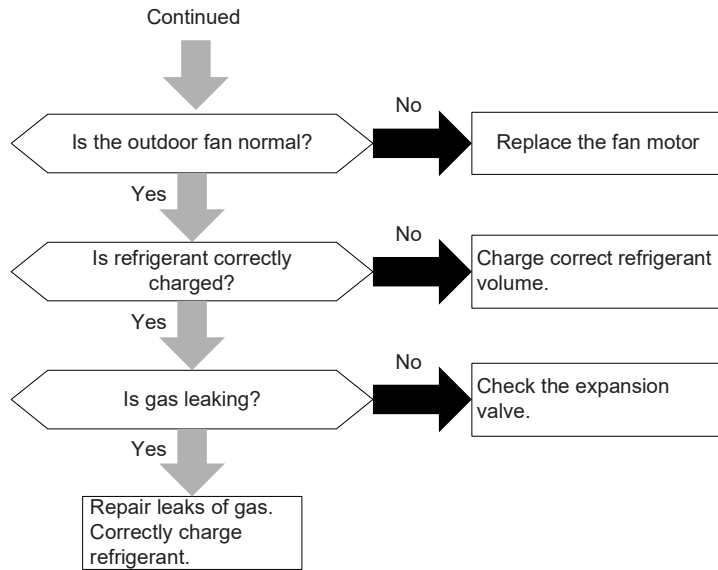

Phenomenon	Cause	Check Item	Action(Turn OFF Main Switch)	
Decrease of Discharge Gas Superheat	Ref. Cycle is Different from the Electrical System	Check ref. cycle and the electrical system.	Repair wiring.	
	Overcharged Refrigerant	Check pressures.	Correctly charge Overcharged Refrigerant refrigerant.	
	Faulty Expansion Valve	Check expansion valve.	Replace expansion valve if faulty.	
	Faulty O.U. main PCB	Fault	Check operation.	Replace electrical box if faulty.
		Disconnected Wires for Expansion Valve	Check connections.	Repair wiring connections.
	Faulty Discharge Gas Thermistor	Fault	Check resistance of thermistor.	Replace thermistor if faulty.
		Incorrect Mounting	Check mounting state.	Correctly mount thermistor.
Incorrect Connection		Check connections.	Remove looseness, replace connector or repair connections.	

Alarm Code	08	Increase in Discharge Gas Temperature of Compressor
------------	----	---

- Alarm code is displayed on the master controller/ the 7-segment of O.U. display PCB / the 7-segment of I.U. PCB1.
- ★ When either of the following conditions occurs, retry operation is performed. However, if it occurs again twice times in the next 60 minutes, this alarm code is displayed;
  - The temperature of the thermistor on the top of the compressor is kept higher than 120°C for 10 minutes.
  - The temperature of the thermistor on the top of the compressor is kept higher than 130°C for 5 seconds.

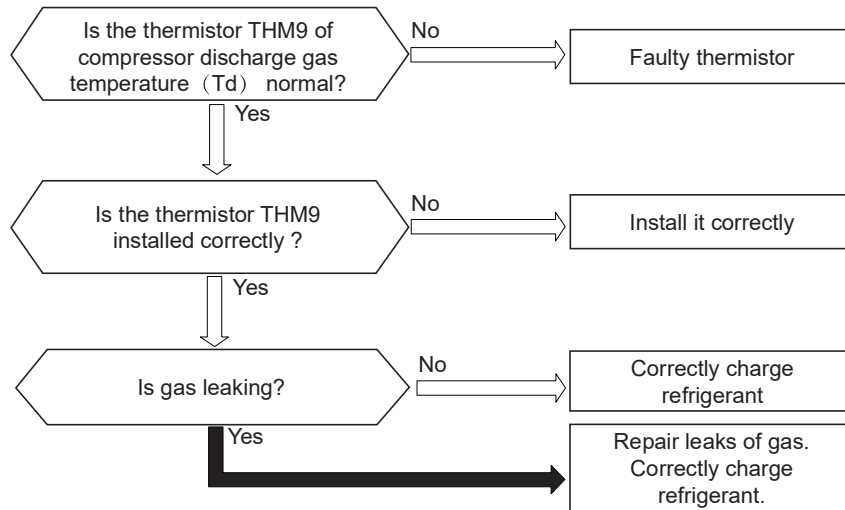

Phenomenon	Cause		Check Item	Action(Turn OFF Main Switch)
Excessively High Discharge Gas Temperature	Undercharge of Refrigerant		Check pressures and EVO	Correctly charge Undercharge of refrigerant.
	Faulty Expansion Valve		Check expansion valve.	Replace expansion valve if faulty.
	Faulty O.U. main PCB	Fault	Check operation.	Replace electrical box if faulty.
		Disconnected Wires for Expansion Valve	Check connections.	Repair wiring connections.
	Faulty Discharge Gas Thermistor	Fault	Check resistance of thermistor.	Replace thermistor if faulty.
		Incorrect Mounting of Thermistor	Check mounting state.	Correctly mount thermistor.
		Incorrect Wiring	Check connections.	Remove looseness, replace connectors or repair connections.

Alarm Code	22	Abnormality of Thermistor for Outdoor Unit Ambient (Ta)
------------	----	---

- Alarm code is displayed on the master controller/ the 7-segment of O.U. display PCB / the 7-segment of I.U. PCB1.
- ★ This alarm code is indicated when a short circuit (less than 0.2kΩ) or disconnection (more than 500kΩ) of the thermistor is detected during the operation.

O.U. main PCB: Outdoor Unit main PCB

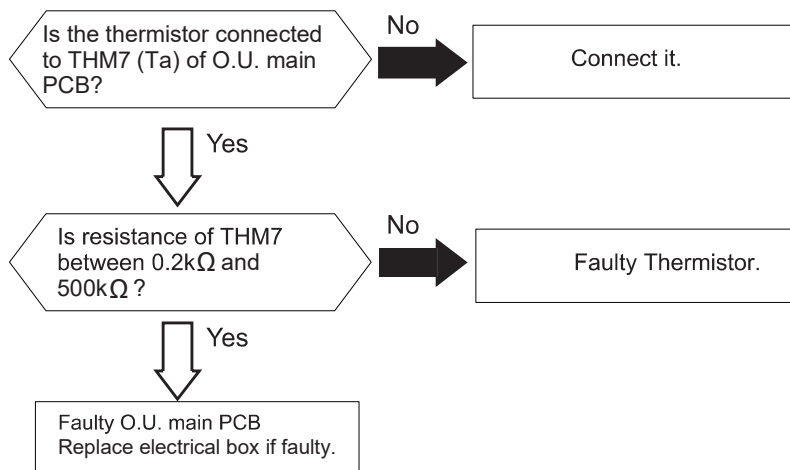

Thermistor Characteristics Ta, Te and Te2

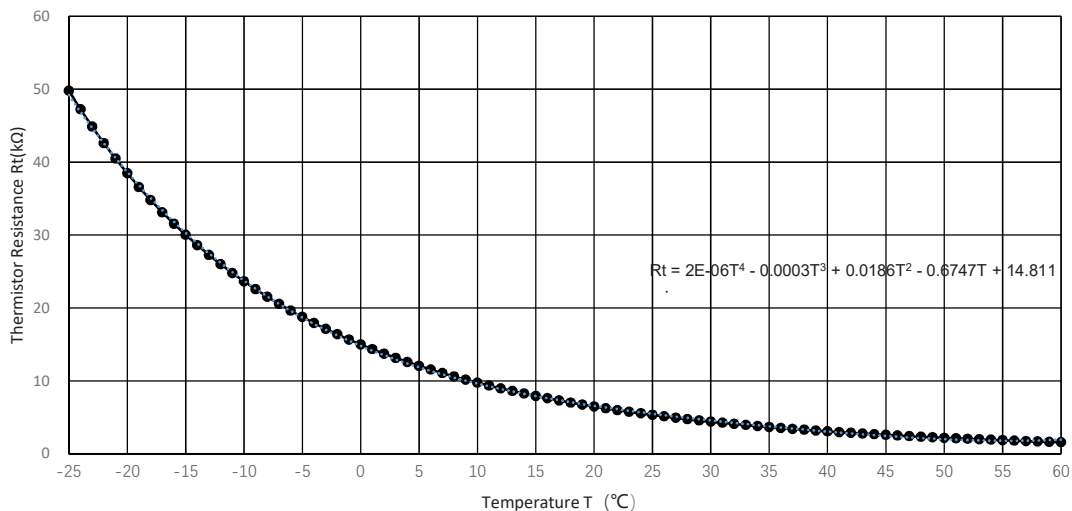

Phenomenon	Cause	Check Item	Action(Turn OFF Main Switch)
Faulty Thermistor for Outdoor Unit Ambient	Fault	Check resistance.	Replace thermistor if faulty.
	Incorrect Connection	Check wiring to O.U. main PCB.	Repair wiring and connections.
Faulty O.U. main PCB		Replace O.U. main PCB and check operation.	Replace O.U. main PCB if faulty.



Alarm Code	23	Abnormality of Thermistor for Compressor Discharge Gas Temperature(Td)
------------	----	--

- Alarm code is displayed on the master controller/ the 7-segment of O.U. display PCB / the 7-segment of I.U. PCB1.
- ★ This alarm code is indicated when a short circuit (less than 0.9kΩ) for a second or disconnection (more than 5946kΩ) of the thermistor is detected during the operation.

O.U. main PCB: Outdoor Unit main PCB

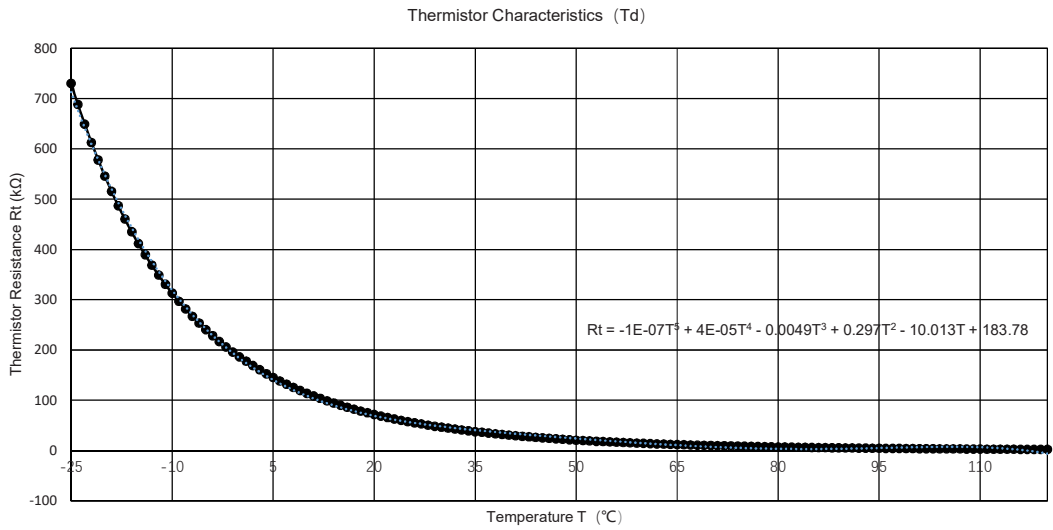
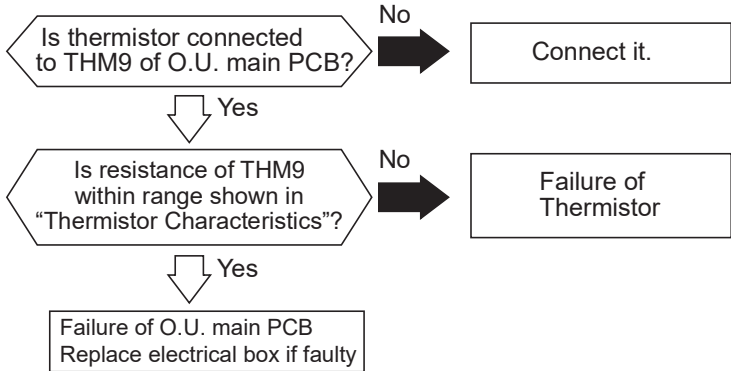

Phenomenon	Cause	Check Item	Action(Turn OFF Main Switch)
Faulty Compressor Discharge Gas Thermistor(Td)	Fault	Check resistance.	Replace thermistor if faulty.
	Incorrect Connection	Check wiring to O.U. main PCB.	Repair wiring and connections.
Faulty O.U. main PCB			Replace O.U. main PCB if faulty.

Alarm Code <b>24</b>	<b>Abnormality of Thermistor of heat exchanger Liquid Pipe (Te)</b>
----------------------	---

- Alarm code is displayed on the master controller/ the 7-segment of O.U. display PCB / the 7-segment of I.U. PCB1.
- ★ This alarm code is displayed when a short circuit (0.24kΩ or less) or disconnection (500kΩ or more) of the thermistor is detected during heating or cooling operation.

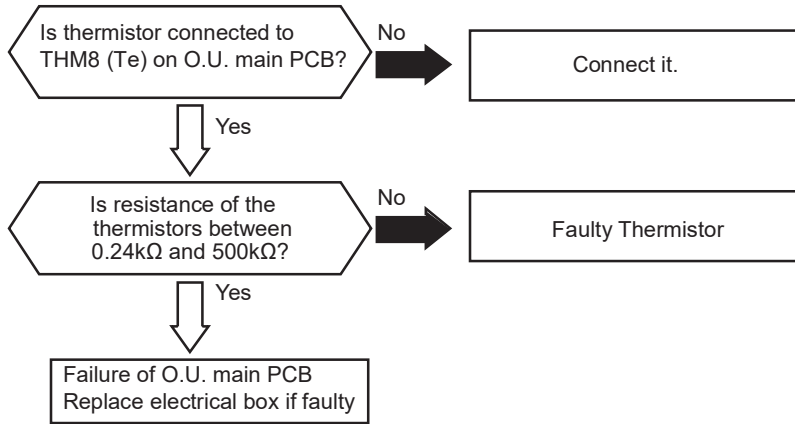

Thermistor Characteristics Ta, Te and Te2

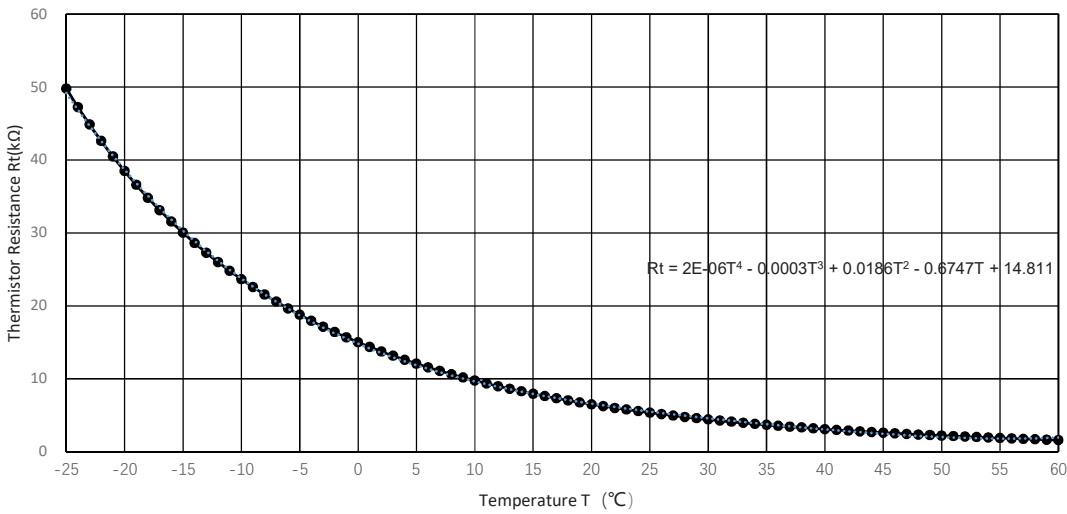

Phenomenon	Cause	Check Item	Action(Turn OFF Main Switch)
Faulty Thermistor for Heat Exchanger Liquid Pipe(Te)	Fault	Check resistance.	Replace thermistor if faulty.
	Incorrect Connection	Check wiring to O.U. main PCB.	Repair wiring and connections.
Faulty O.U. main PCB		Replace O.U. main PCB and check operation.	Replace O.U. main PCB if faulty.

Alarm Code	25	Abnormality of Thermistor of heat exchanger Liquid Pipe (Te2)
------------	----	---

- Alarm code is displayed on the master controller/ the 7-segment of O.U. display PCB / the 7-segment of I.U. PCB1.
- ★ This alarm code is displayed when a short circuit (0.24kΩ or less) or disconnection (500kΩ or more) of the thermistor is detected during heating or cooling operation.

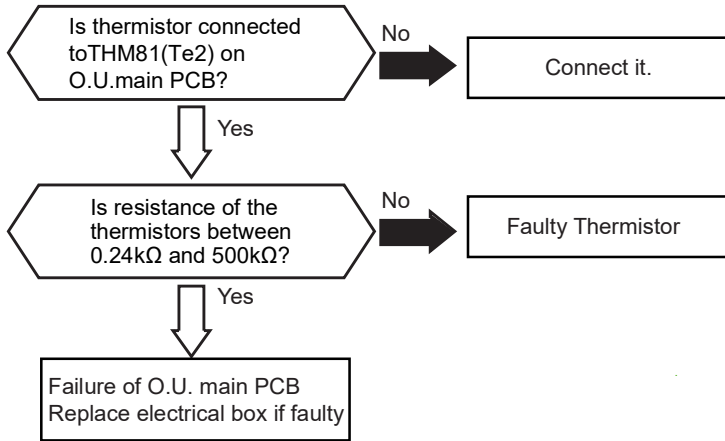

Phenomenon	Cause	Check Item	Action(Turn OFF Main Switch)
Faulty Thermistor for Heat Exchanger Liquid Pipe(Te2)	Fault	Check resistance.	Replace thermistor if faulty.
	Incorrect Connection	Check wiring to O.U. main PCB.	Repair wiring and connections.
Faulty O.U. main PCB		Replace O.U. main PCB and check operation.	Replace electrical box if faulty.

Thermistor Characteristics Ta,Te and Te2

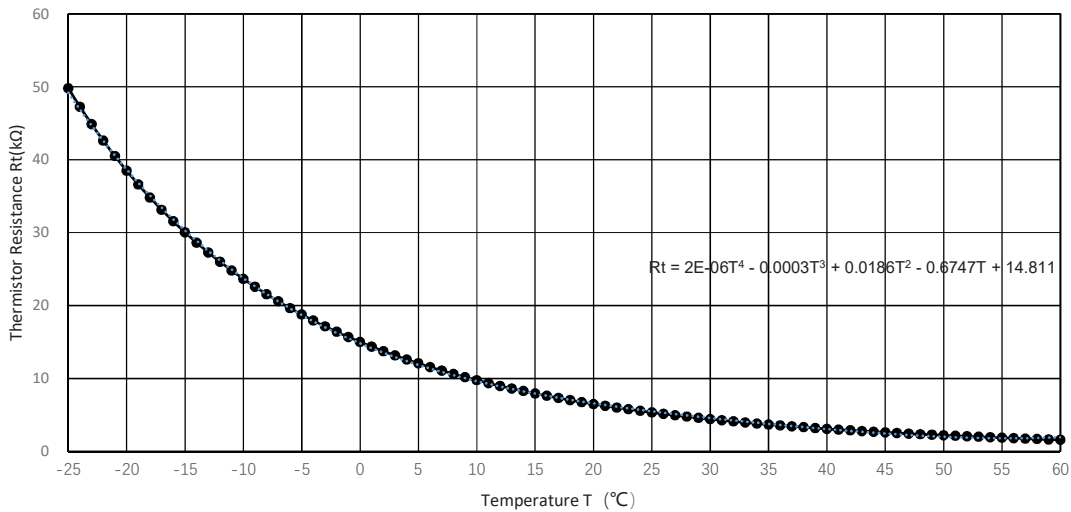

Alarm Code	31	Incorrect Capacity Setting of Indoor Unit and Outdoor Unit
------------	----	--

- Alarm code is displayed on the master controller/ the 7-segment of O.U. display PCB / the 7-segment of I.U. PCB1.
  - ★ This alarm code is indicated when the capacity setting dip switch, DSW3 on the O.U. display PCB is not set (all the settings from #1 to #4 are OFF) or set incorrectly.
  - ★ This alarm code is indicated when the total indoor unit capacity is smaller than 50% or greater than 135% of the combined outdoor unit capacity.

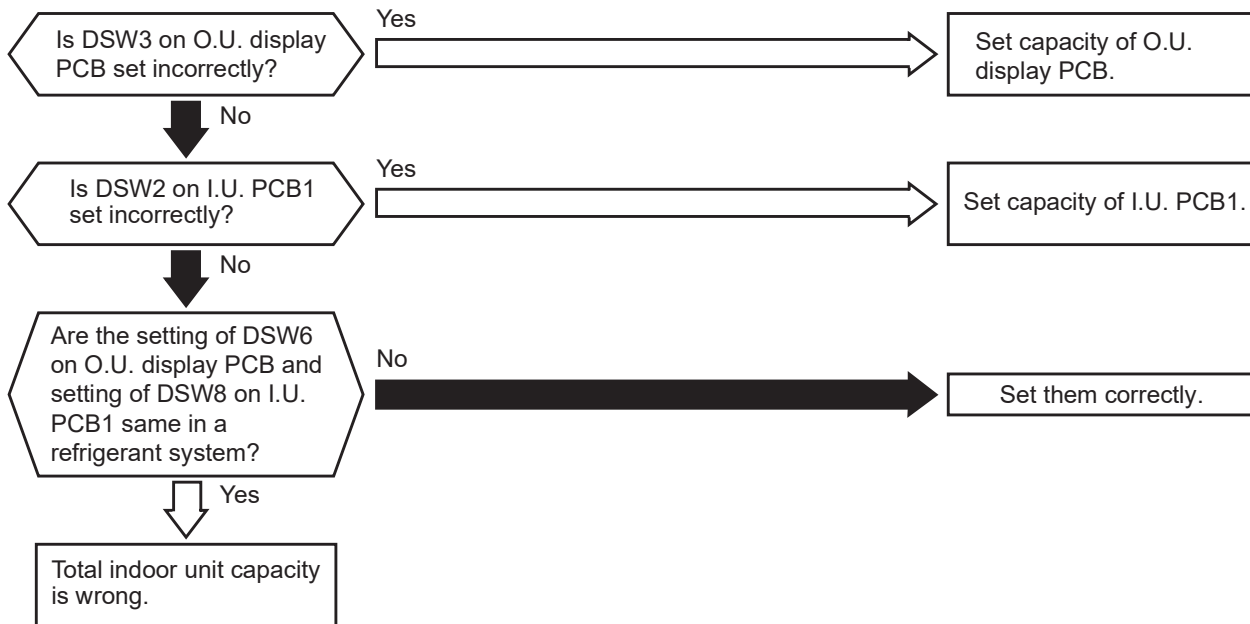

Phenomenon	Cause	Check Item	Action(Turn OFF Main Switch)
Incorrect Capacity Setting of Indoor Unit		Check capacity setting on I.U. PCB1.	Correctly set DIP switch, DSW2.
Incorrect Capacity Setting of Outdoor Unit		Check capacity setting on O.U. display PCB.	Correctly set DIP switch, DSW3.
Refrigeration Cycle Setting of Outdoor Unit and Indoor Unit is Different		Check refrigeration cycle setting on O.U. display PCB and I.U. PCB1.	Set them correctly.
Indoor Unit Capacity Connected to the Outdoor Unit is Beyond Permissible Range		Check outdoor unit model by calculating indoor unit capacity.	Ensure that total indoor unit capacity is from 50% to 135%.

Alarm Code	35	Incorrect Indoor Unit No. Setting
------------	----	-----------------------------------

- Alarm code is displayed on the master controller/ the 7-segment of O.U. display PCB / the 7-segment of I.U. PCB1.
  - ★ This alarm code is displayed when the duration of automatic addressing of indoor unit exceeds 5 minutes after power-on of outdoor unit.
  - ★ This alarm code is displayed when the number of connected indoor units exceeds the maximum allowed.
  - ★ This alarm code is displayed when refrigerant system No. set by DSW6 on O.U. display PCB in the same H-NET.

**NOTE:**

- In the case of H-NET system, this alarm code may be displayed when DSW6 (for refrigerant system No. setting) on the O.U. display PCB and DSW8 (for refrigerant system No. setting) on the indoor unit PCB1 are not set correctly. In this case, turn OFF the power supply and set them correctly, and turn ON the power supply again.

Alarm Code	43	Activation of Low Compression Ratio Protection Device
------------	----	---

- Alarm code is displayed on the master controller/ the 7-segment of O.U. display PCB / the 7-segment of I.U. PCB1.
- ★ If the pressure ratio  $\epsilon^{*1}$  is less than 1.0 for 1 minute or less than 1.5 for 5 minute, the compressor stops. The operation automatically restarts after three minutes. If this occurs again twice in the next 60 minutes, this alarm code is displayed.
- \*1) Pressure Ratio  $\epsilon = (Pd[MPa] + 0.1)/(Ps[MPa] + 0.06)$  )  
 Pd: high pressure (discharge pressure)  
 Ps: low pressure (suction pressure)

O.U. PCB: Outdoor Unit PCB

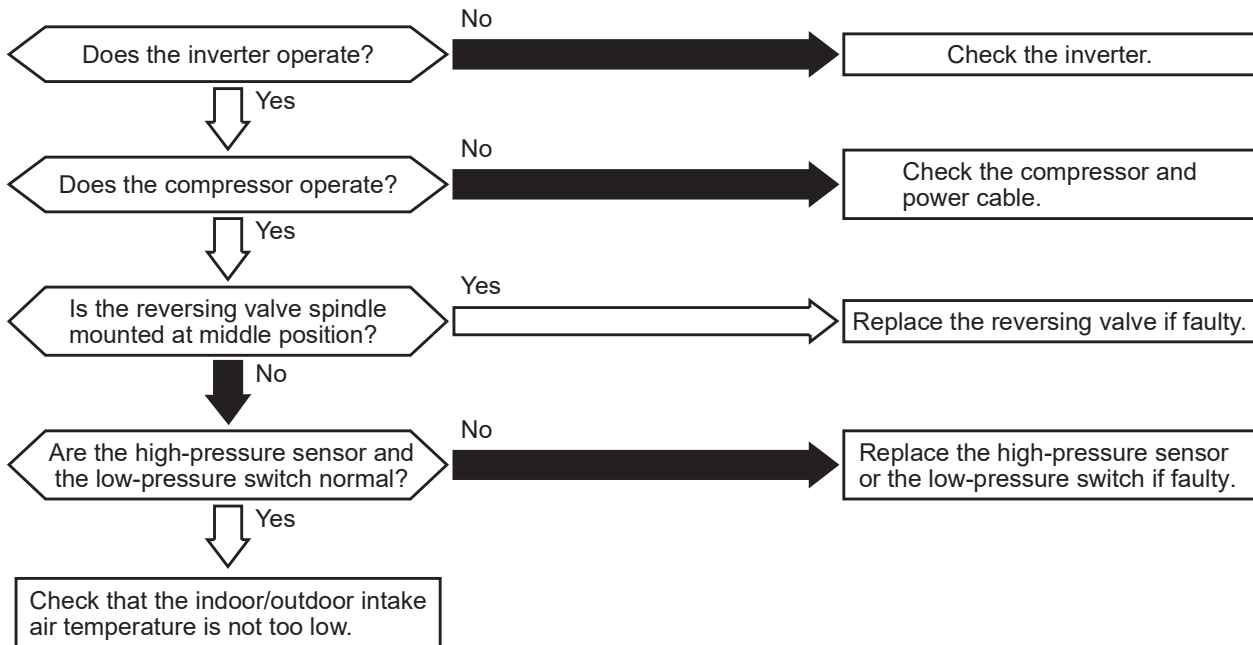

Phenomenon	Cause	Check Item	Action(Turn OFF Main Switch)
Excessively Low Compression Ratio	Inverter is not Functioning	Check inverter.	Repair faulty part.
	Compressor is not Operating	Check compressor.	Replace comp. if faulty.
	Valve Stoppage at Middle Position of Reversing Valve	Measure suction pipe temp. of reversing valve.	Replace reversing valve if faulty.
	Excessively Low Indoor Intake Air Temperature	Check indoor unit and outdoor unit air temp. thermistor.	Replace thermistor if faulty.

Alarm Code	46	Activation of High Pressure Decrease Protection Device
------------	----	--

- Alarm code is displayed on the master controller/ the 7-segment of O.U. display PCB / the 7-segment of I.U. PCB1.
- ★ When the discharge pressure (Pd) continues to be lower than 1.0MPa for 30 minutes or continues to be lower than 0.3MPa for 4 minutes, the compressors stop and then retry the operation after 3 minutes. This alarm code is indicated when this occurs once more within the next 35 minutes.

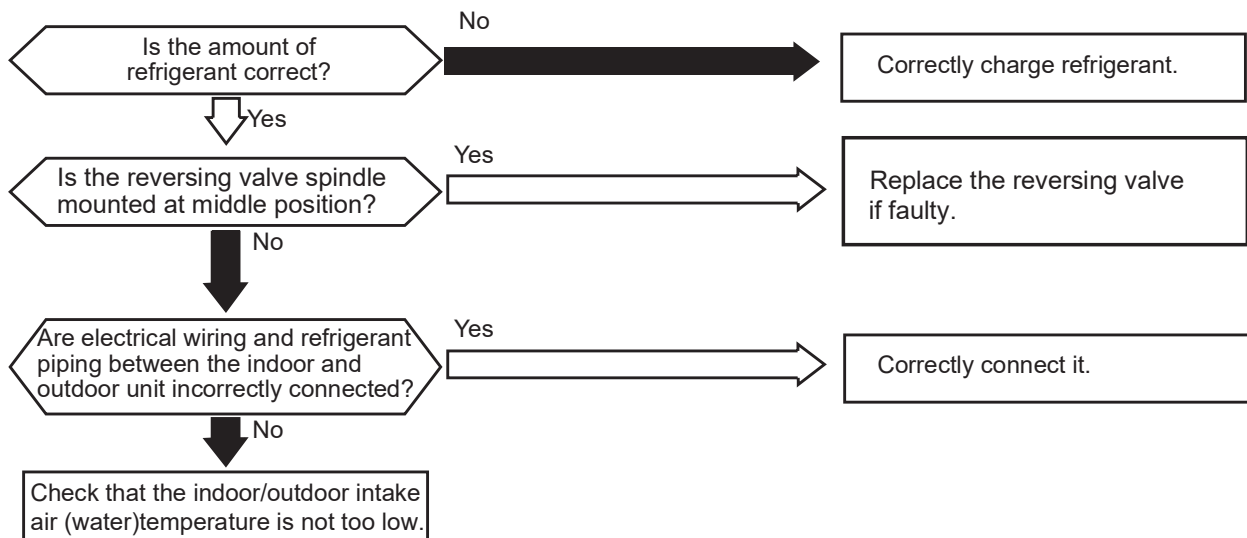

Phenomenon	Cause	Check Item	Action(Turn OFF Main Switch)
Excessively Low Discharge Pressure	Shortage of Ref.	Check charged ref. volume or check for leakage	Repair leakage and correctly charge.
	Valve Stoppage at Middle Position of Reversing Valve	Measure suction pipe temp. of reversing valve.	Replace reversing valve if faulty.
	Incorrect Connection between Indoor Unit and Outdoor Unit	Check the wiring	Correctly connect them.
	Excessively Low Indoor/ outdoor Intake Air(water) Temperature	Check indoor unit and outdoor unit temperature thermistor.	Replace thermistor if faulty.

Alarm Code	47	Activation of Low Pressure Decrease Protection Switch (Vacuum Operation Protection)
------------	----	--

- Alarm code is displayed on the master controller/ the 7-segment of O.U. display PCB / the 7-segment of I.U. PCB1.
- ★ This alarm code is indicated when a suction pressure (Ps) is lower than 0.09MPa and the same condition occurs twice or more within one hour.
- ★ This alarm code is indicated when low pressure switch(PSL) is activated and the same condition occurs three times or more within 80minutes.

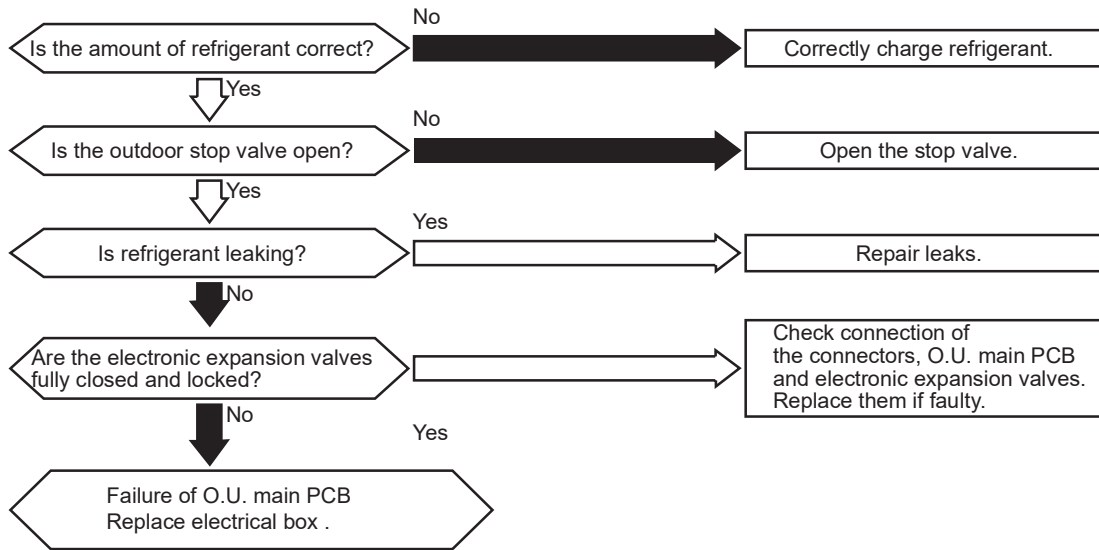

Phenomenon	Cause		Check Item	Action(Turn OFF Main Switch)
Excessively Low Suction Pressure (in Vacuum)	Shortage of Ref.		Check charged ref. volume or check for leakage.	Repair leakage and correctly charge.
	Closed Stop Valve		Check stop valve.	Open stop valve.
	Incorrect Connection between Indoor Unit and Outdoor Unit		Check electrical system and ref. cycle.	Correctly connect between indoor unit and outdoor unit.
	Locked Expansion Valve with Fully Closed		Check connector for O.U. main PCB.	Repair connector for O.U. main PCB1 or expansion valve. Replace it if faulty.
	Closed Expansion Valve by Disconnecting Td Thermistor		Check Td thermistors for compressors and measure Td thermistor resistance.	Repair or replace Td thermistor.
Internal Thermostat for Outdoor Fan is Activated in Heating Operation	Faulty Outdoor Fan Motor		Measure coil resistance and insulation resistance	Replace outdoor fan motor if faulty.
	Faulty Internal Thermostat	Fault	Check for conduction after temperature of outdoor fan motor is decreased.	Replace outdoor fan motor.
		Incorrect Contact	Measure resistance by tester.	Remove looseness and replace connector.
		Incorrect Contact	Check connection.	Connect it correctly.



Alarm Code	48	Activation of Inverter Overcurrent Protection Device (2)
------------	----	--

- Alarm code is displayed on the master controller/ the 7-segment of O.U. display PCB / the 7-segment of I.U. PCB1.

★ If instantaneous overcurrent (Cause code of inverter stoppage = 2) occurs on inverter, the compressor stops. The operation automatically restarts after three minutes. If this occurs again five times in the next 30 minutes, this alarm code is displayed.

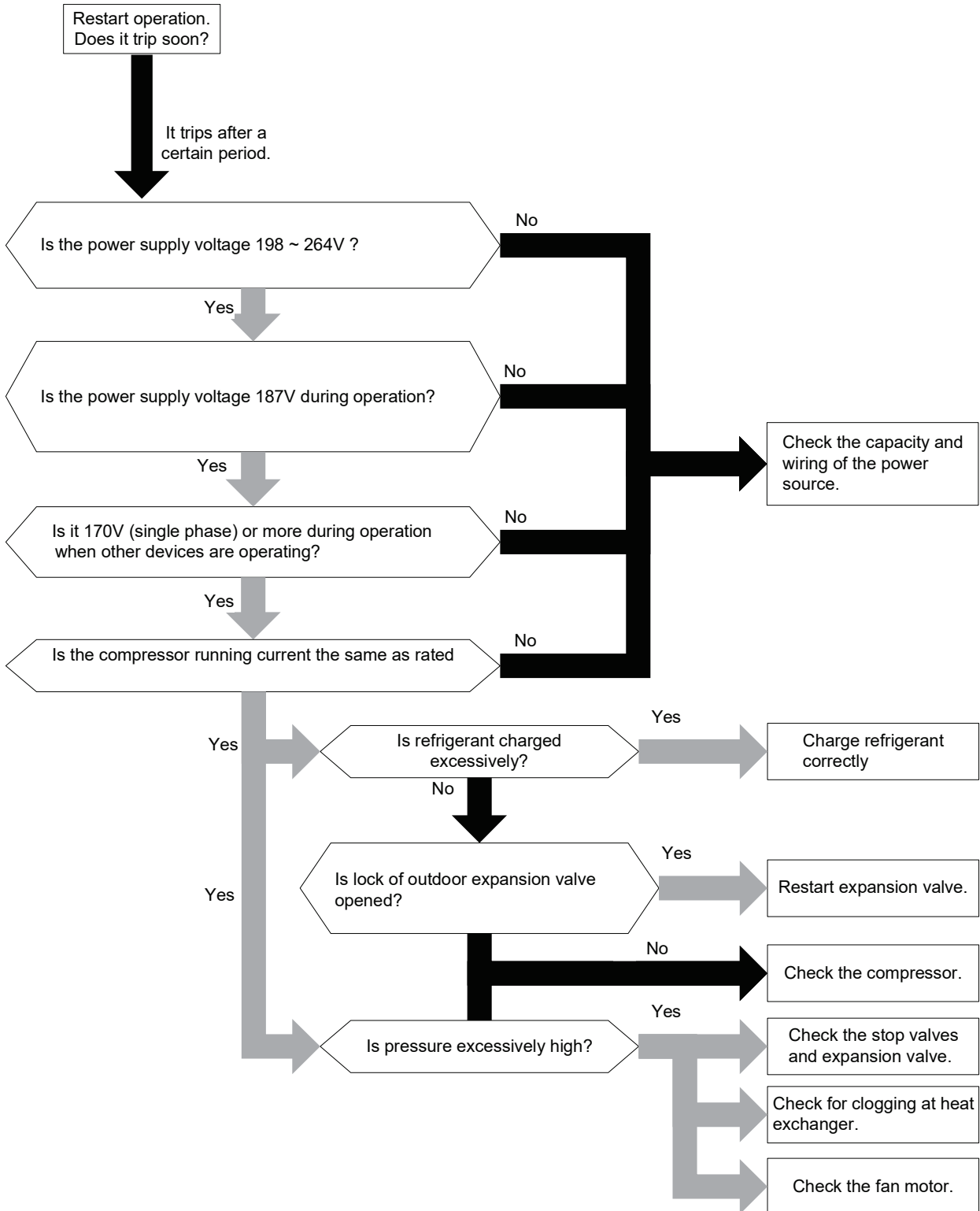

Alarm Code	51	Abnormality of Current Sensor
------------	----	-------------------------------

- Alarm code is displayed on the master controller/ the 7-segment of O.U. display PCB / the 7-segment of I.U. PCB1.
- ★ If abnormal fault of sampling circuit (Cause code of inverter stoppage = 8) occurs on inverter , the compressor stops. The operation automatically restarts after three minutes. If this occurs again 2 times in the next 30 minutes, this alarm code is displayed.

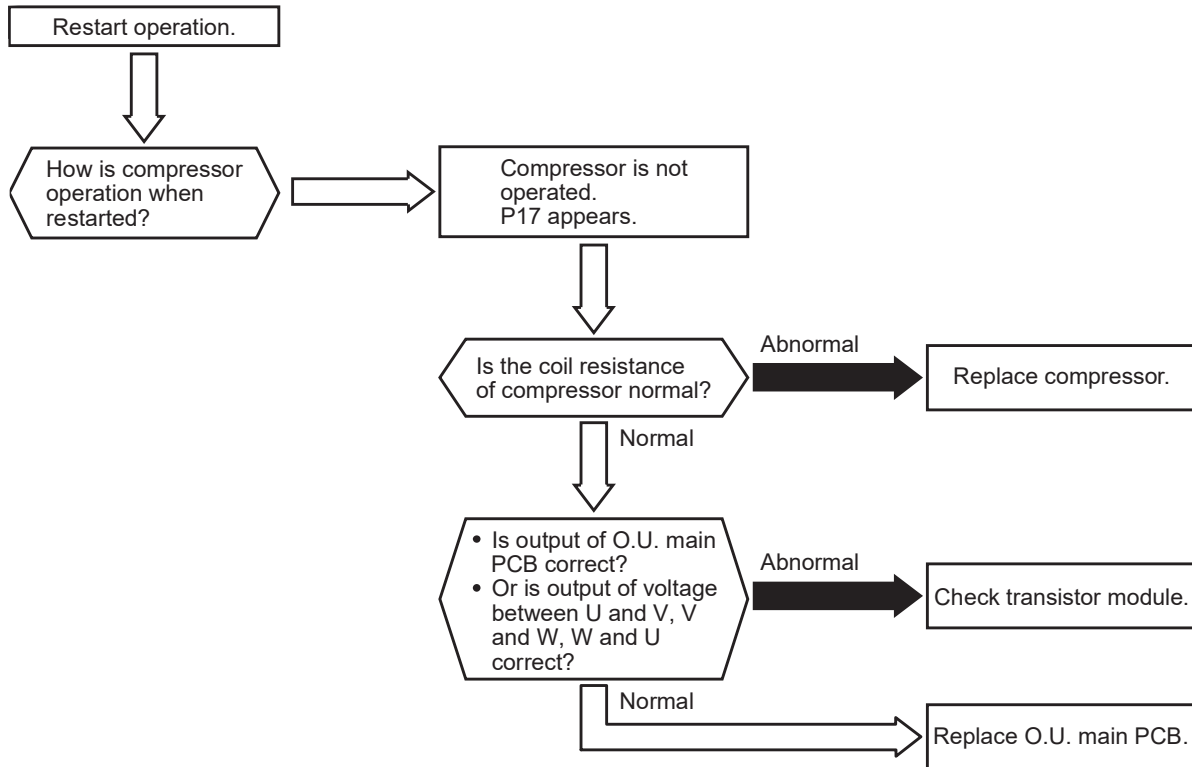

Alarm Code	53	Inverter Error Signal Detection
------------	----	---------------------------------

• Alarm code is displayed on the master controller/ the 7-segment of O.U. display PCB / the 7-segment of I.U. PCB1.

★ If the following abnormality is detected on inverter , the compressor stops. The operation automatically restarts after three minutes. If this occurs again 6 times in the next 30 minutes, this alarm code is displayed.

- ① IPM Error(Cause code of inverter stoppage = 1)
- ② Step-Out Detection(Cause code of inverter stoppage = 21)
- ③ Abnormal PFC Hardware(Cause code of inverter stoppage = 23).

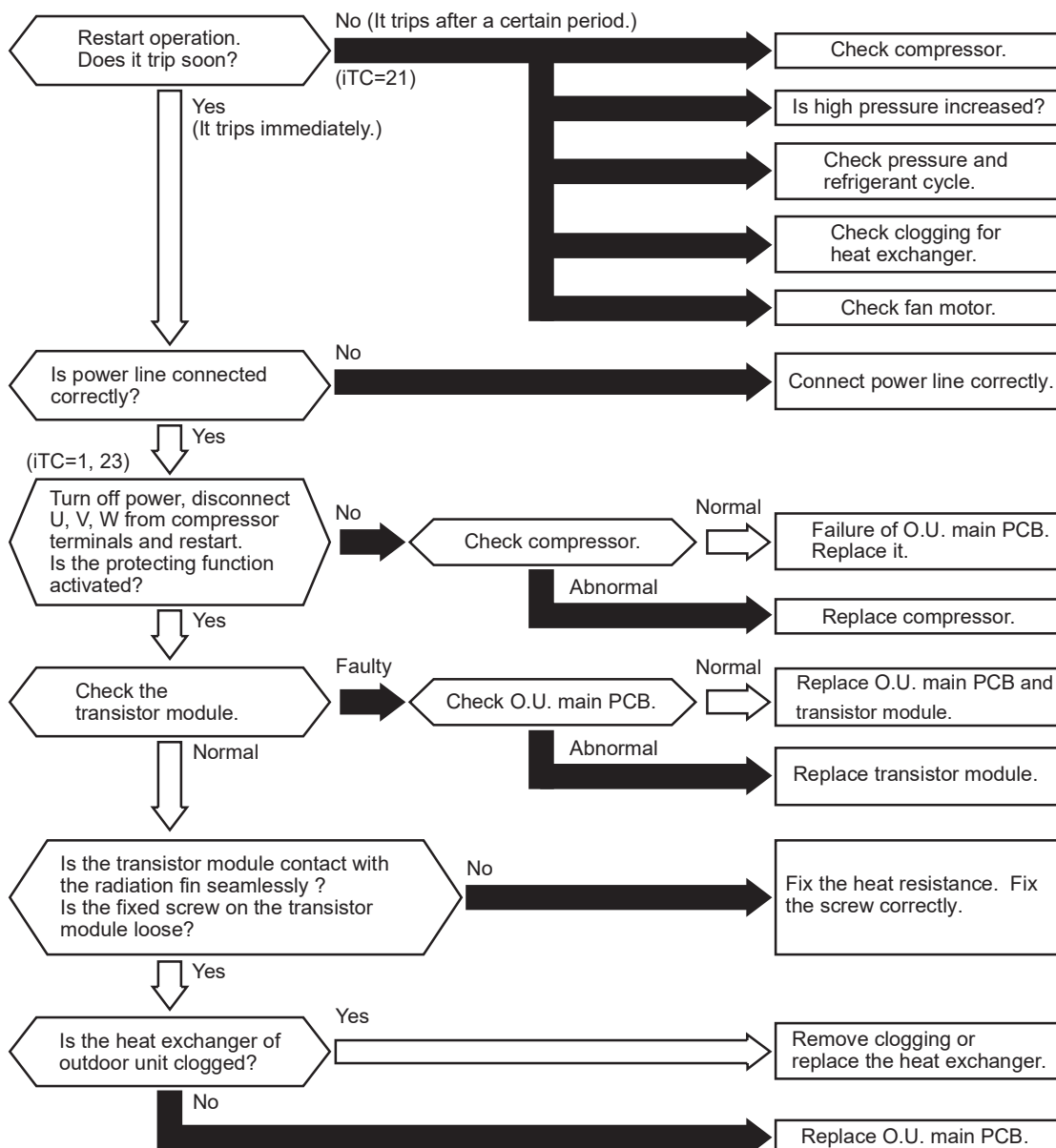

Alarm Code	54	Abnormality of Inverter Fin Temperature
------------	----	---

- Alarm code is displayed on the master controller/ the 7-segment of O.U. display PCB / the 7-segment of I.U. PCB1.

★ When the following condition occurs three times in 30 minutes, the operation stops and this alarm code is displayed. If this occurs less than three times in 30 minutes, the operation automatically restarts.

Condition of Activation:

- ① Inverter fin thermistor protection activation (Cause code of inverter stoppage = 3) .The temperature of inverter fin exceeds 75°C.
- ② TFin sensor Error (Cause code of inverter stoppage = 32) the temperature sensor is open or broken.

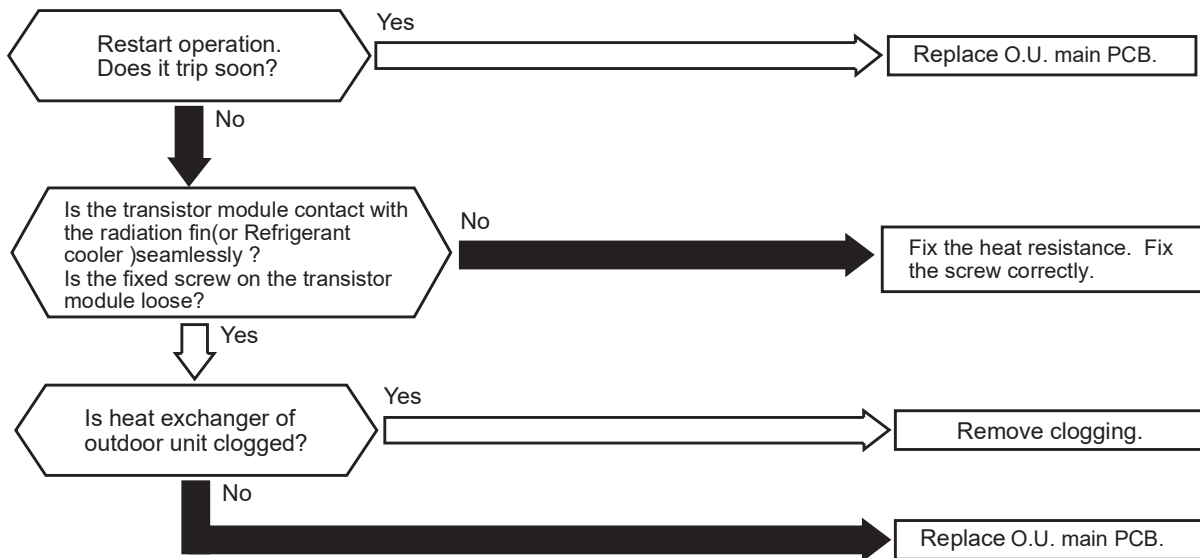

Alarm Code	55	Inverter Failure
------------	----	------------------

- Alarm code is displayed on the master controller/ the 7-segment of O.U. display PCB / the 7-segment of I.U. PCB1.

★ This alarm code is indicated when the following phenomenon occurs three times in 30 minutes.  
(Retry operation is performed for the first two times.)

Condition of Activation:

- ① When there is no current in one phase of the compressor, or the current between phases is unbalanced, the compressor phase failure (Cause code of inverter stoppage = 13).
- ② EERPOM Error or Abnormal of Key Parameters of Compressor and PFC (Cause code of inverter stoppage = 22)
- ③ Abnormal Chip Check(Cause code of inverter stoppage = 33)



Alarm Code	57	Abnormality of Fan Motor
------------	----	--------------------------

- Alarm code is displayed on the master controller/ the 7-segment of O.U. display PCB / the 7-segment of I.U. PCB1.
  - ★ When the following condition occurs three times in 30 minutes, the operation stops and this alarm code is displayed. If this occurs less than three times in 30 minutes, the operation automatically restarts.
- Condition of Activation:
- (1) Abnormal speed of Fan-motor detection (Cause code of inverter stoppage = 28)

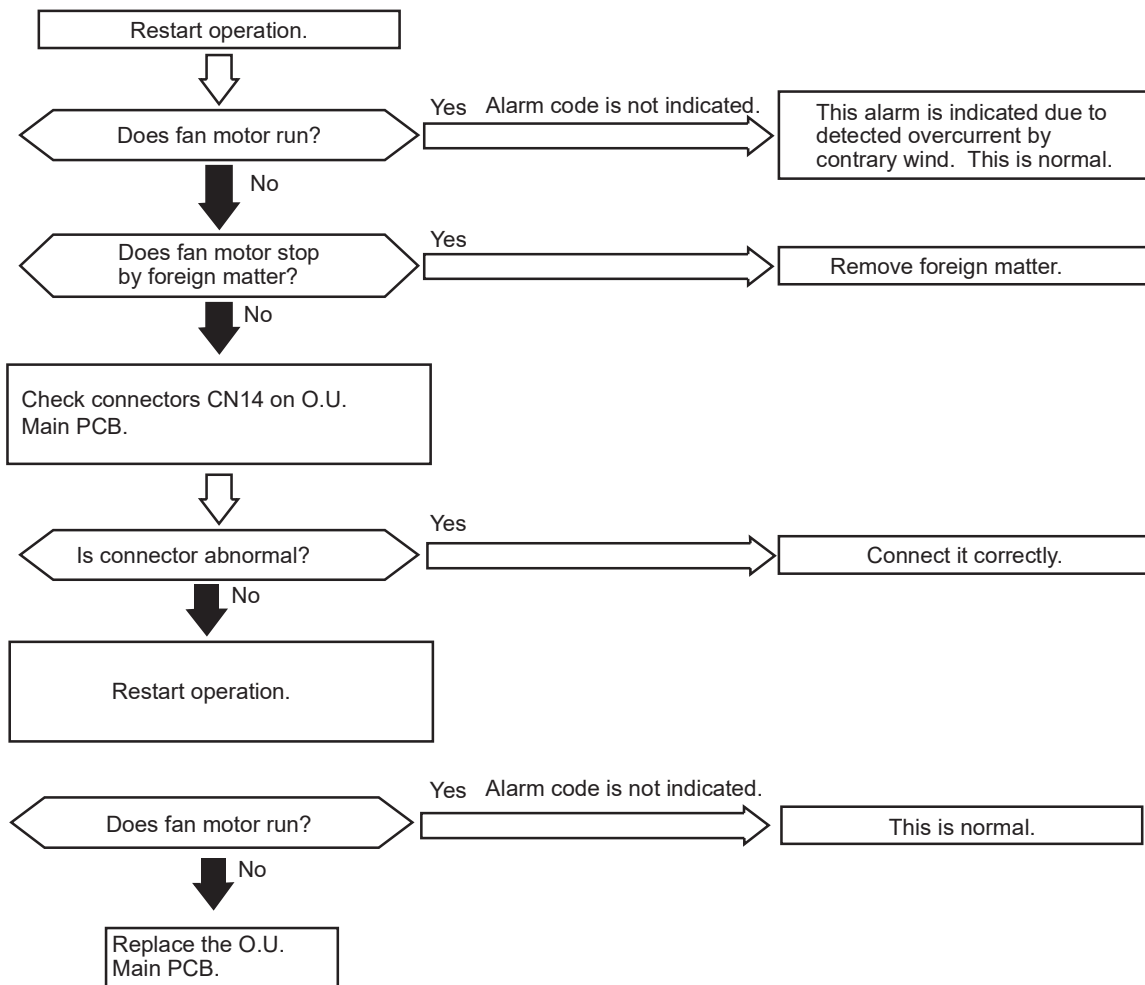

Alarm Code	EE	Compressor Protection
------------	----	-----------------------

★ This alarm code appears when one of the following alarms occurs three times within 6 hours, which may result in serious compressor damages, if the outdoor unit is continuously operated without removing the cause.

Alarm Code	Content of Abnormality
02	Activation of Protection Device (High Pressure Switch) in Outdoor Unit
07	Decrease in Discharge Gas Superheat
08	Excessively High Discharge Gas Temperature at Top of Compressor
43	Activation of Pressure Ratio Decrease Protection
44	Activation of Low Pressure Increase Protection
45	Activation of High Pressure Increase Protection Device
47	Activation of Low Pressure Decrease Protection

These alarms are able to be checked by the CHECK Mode. Follow the action indicated in each alarm chart. These alarms are cleared only by turning OFF the main power supply to the system. Do not restart the operation without taking any necessary action, since there is a possibility of causing serious damages to the compressors.

## 1.2.3.2 Troubleshooting of Alarm Code (I.U.)

Alarm code	<b>11</b>	Inlet Water thermistor (Tiw) abnormality
------------	-----------	--

- Alarm code is displayed on the master controller/ the 7-segment of O.U. display PCB / the 7-segment of I.U. PCB1.
- This alarm code is indicated when a short circuit (less than 0.24kΩ) or disconnection (more than 840kΩ) of the thermistor is detected during the heating or cooling operation. The operation is automatically restarted when the malfunction is removed.
- Reset the unit to release the alarm.

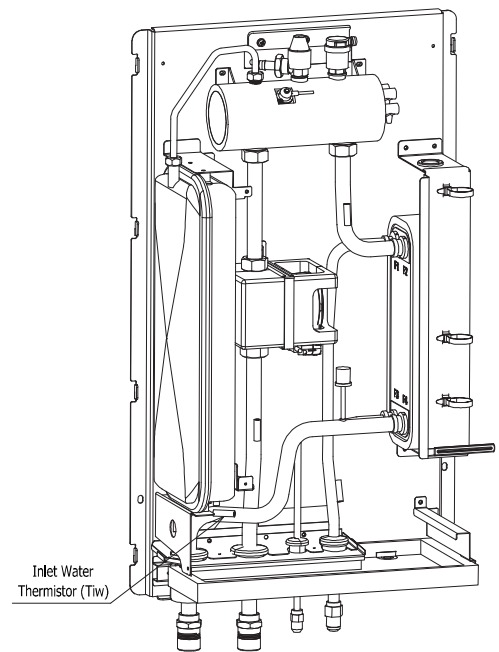
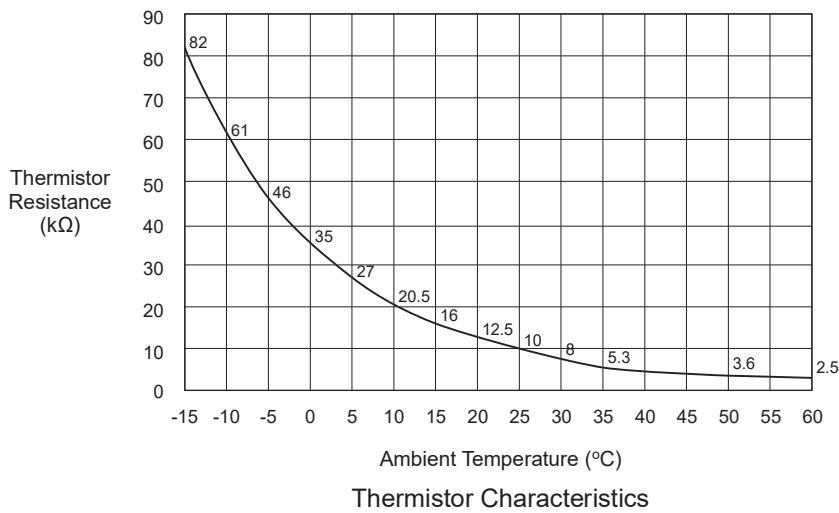



Alarm code	12	Outlet Water Thermistor (Tow) abnormality
------------	----	---

- Alarm code is displayed on the master controller/ the 7-segment of O.U. display PCB / the 7-segment of I.U. PCB1.
- This alarm code is indicated when a short circuit (less than 0.24kΩ) or disconnection (more than 840kΩ) of the thermistor is detected during the heating or cooling operation. The operation is automatically restarted when the malfunction is removed.
- Reset the unit to release the alarm.

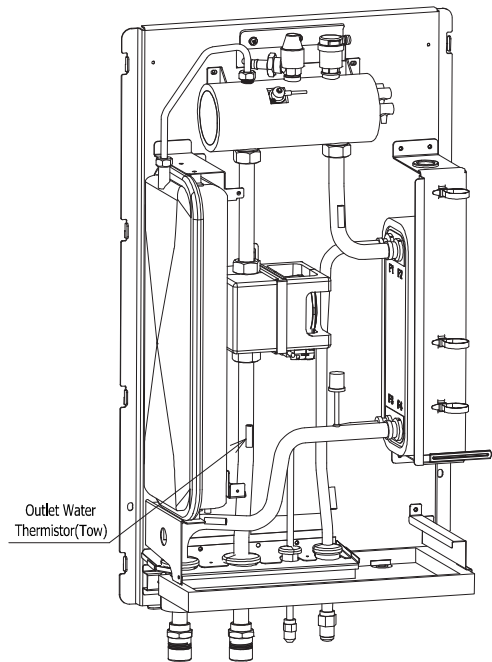
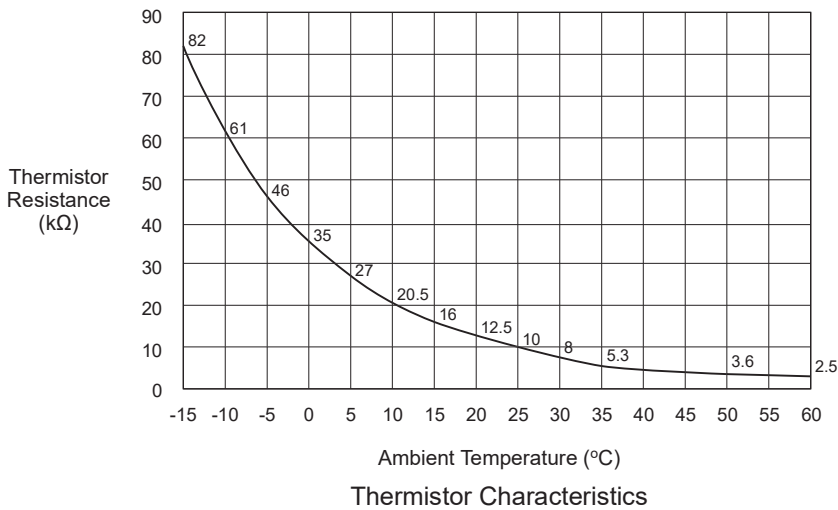

Alarm code	13	Liquid Refrigerant Pipe Thermistor(TL) abnormality
------------	----	--

- Alarm code is displayed on the master controller/ the 7-segment of O.U. display PCB / the 7-segment of I.U. PCB1.
- This alarm code is indicated when a short circuit (less than 0.24kΩ) or disconnection (more than 840kΩ) of the thermistor is detected during the heating or cooling operation. The operation is automatically restarted when the malfunction is removed.
- Reset the unit to release the alarm.

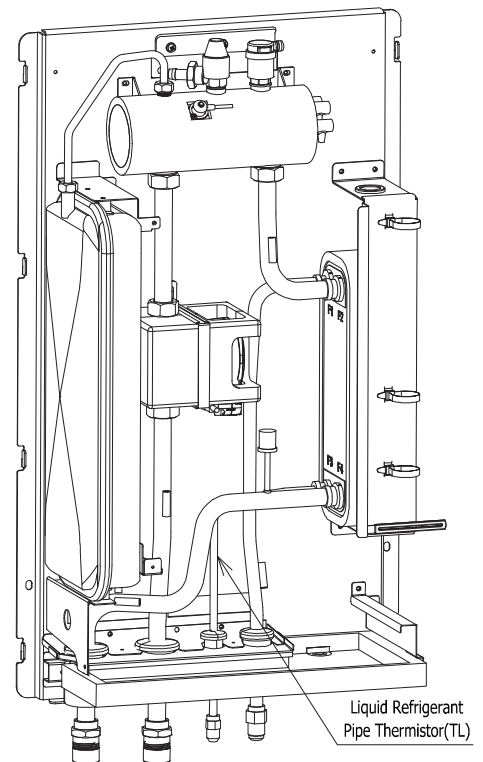
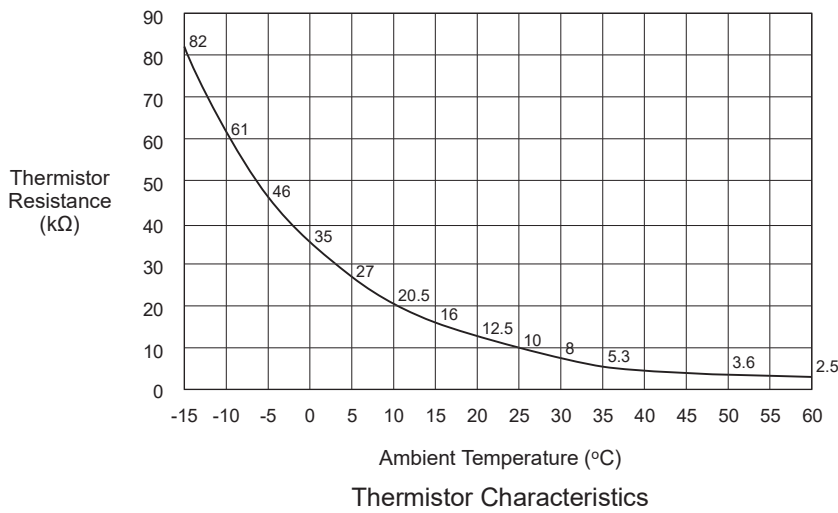

Alarm code	14	Gas Refrigerant Pipe Thermistor(Tg) abnormality
------------	----	---

- Alarm code is displayed on the master controller/ the 7-segment of O.U. display PCB / the 7-segment of I.U. PCB1.
- This alarm code is indicated when a short circuit (less than 0.24kΩ) or disconnection (more than 840kΩ) of the thermistor is detected during the heating or cooling operation. The operation is automatically restarted when the malfunction is removed.
- Reset the unit to release the alarm.

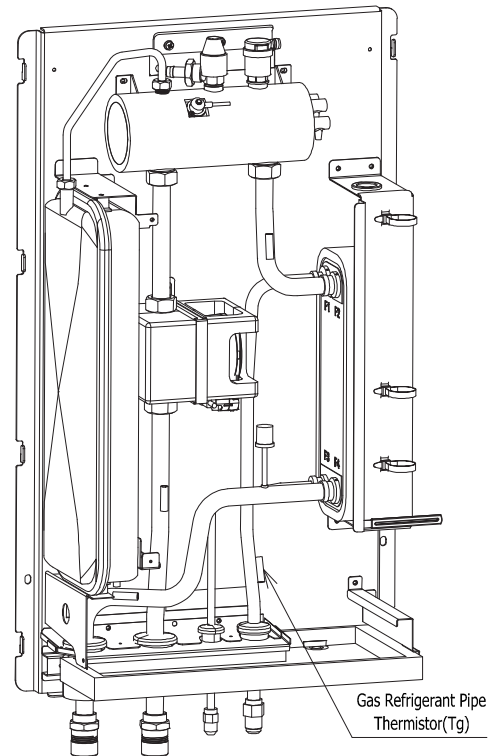
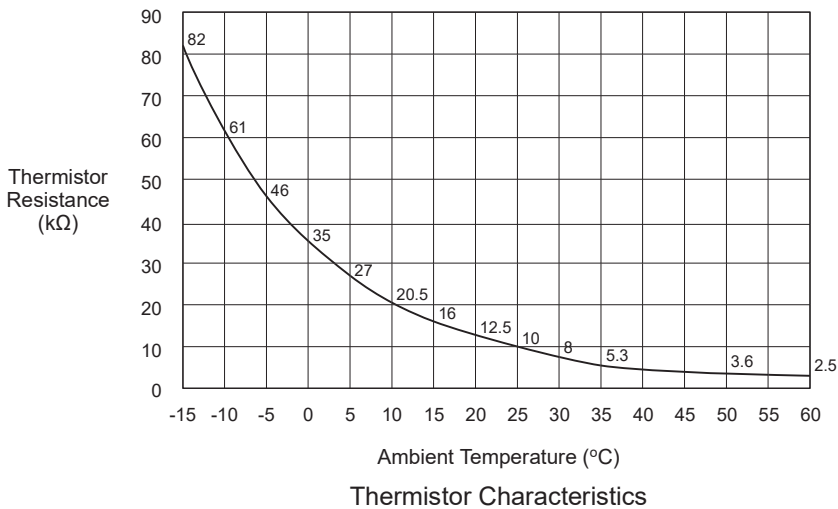

Alarm code	16	DHW Thermistor(TDHW) abnormality
------------	----	----------------------------------

- Alarm code is displayed on the master controller/ the 7-segment of O.U. display PCB / the 7-segment of I.U. PCB1.
- This alarm code is indicated when a short circuit (less than 0.24kΩ) or disconnection (more than 840kΩ) of the thermistor is detected during the heating or cooling operation. The operation is automatically restarted when the malfunction is removed.
- Reset the unit to release the alarm.

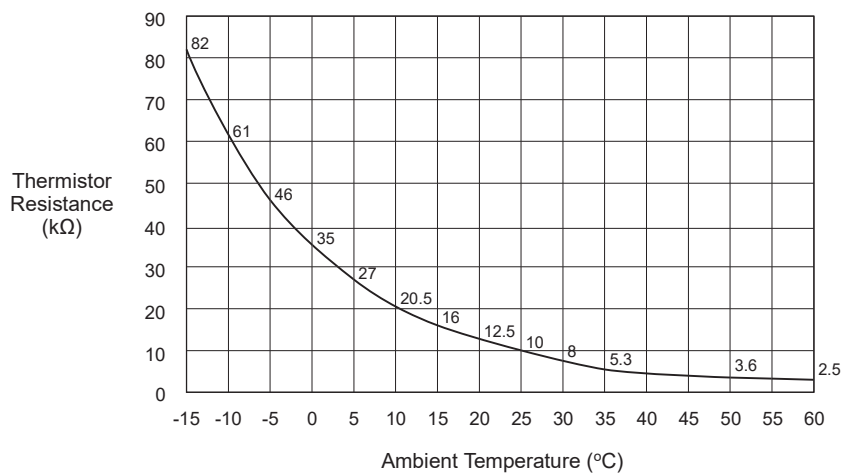
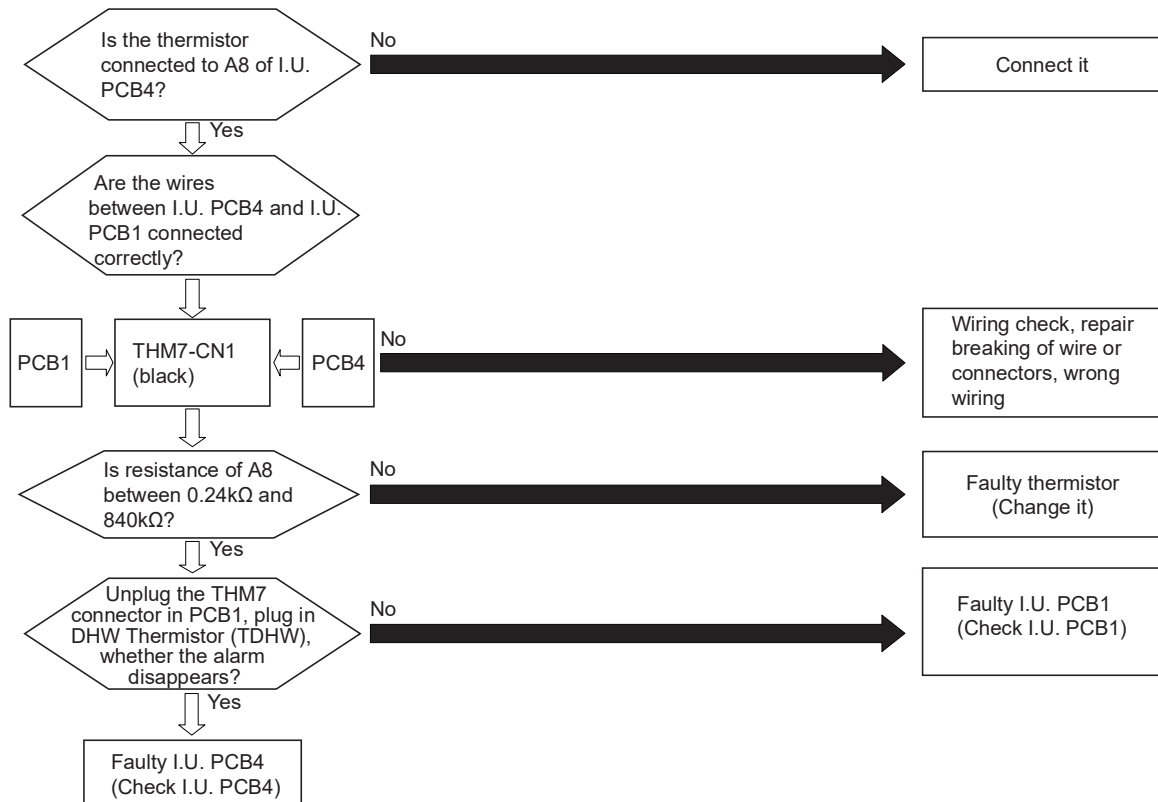

Thermistor Characteristics

Alarm code	17	Outlet HP Water Thermistor(TowHP) abnormality
------------	----	---

- Alarm code is displayed on the master controller/ the 7-segment of O.U. display PCB / the 7-segment of I.U. PCB1.
- This alarm code is indicated when a short circuit (less than 0.24kΩ) or disconnection (more than 840kΩ) of the thermistor is detected during the heating or cooling operation. The operation is automatically restarted when the malfunction is removed.
- Reset the unit to release the alarm.

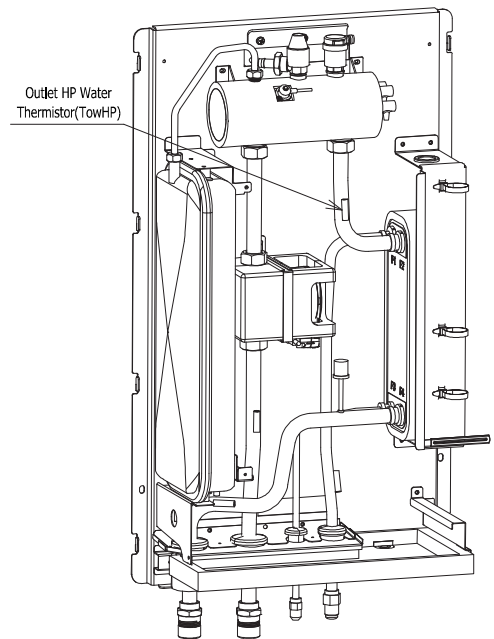
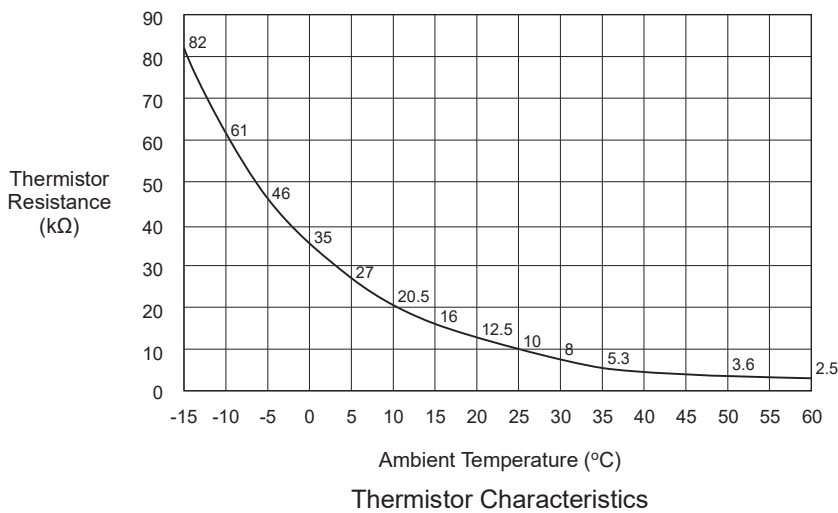
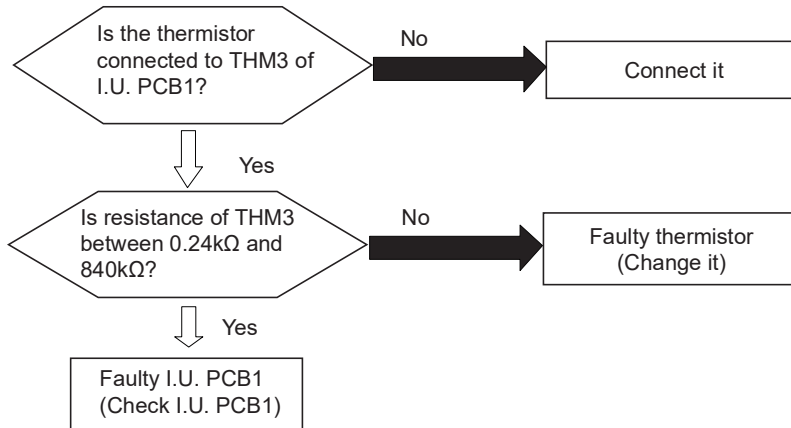

Alarm code	<b>18</b>	Water Pressure Sensor(Pw) Abnormality
------------	-----------	---------------------------------------

- Alarm code is displayed on the master controller/ the 7-segment of O.U. display PCB / the 7-segment of I.U. PCB1.
- This alarm code is indicated when the pressure sensor voltage decreases to 0.1V or less or increases to 4.9V or more during running.
- Reset the unit to release the alarm.

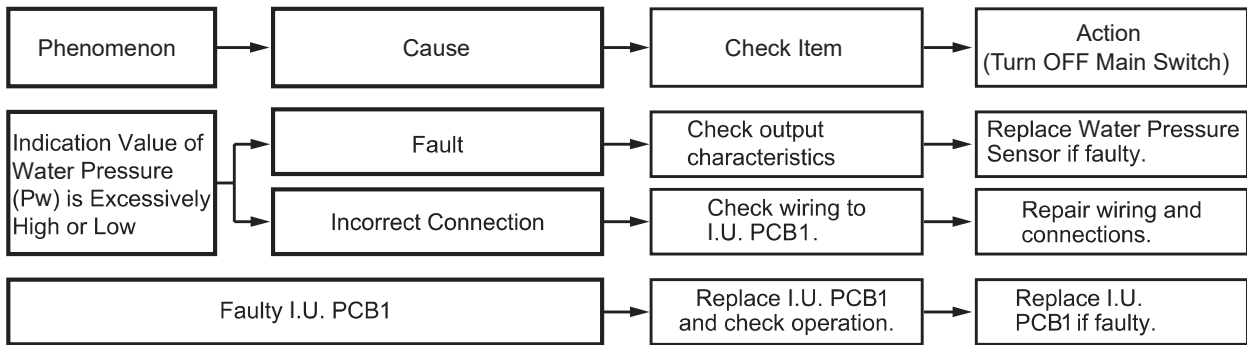
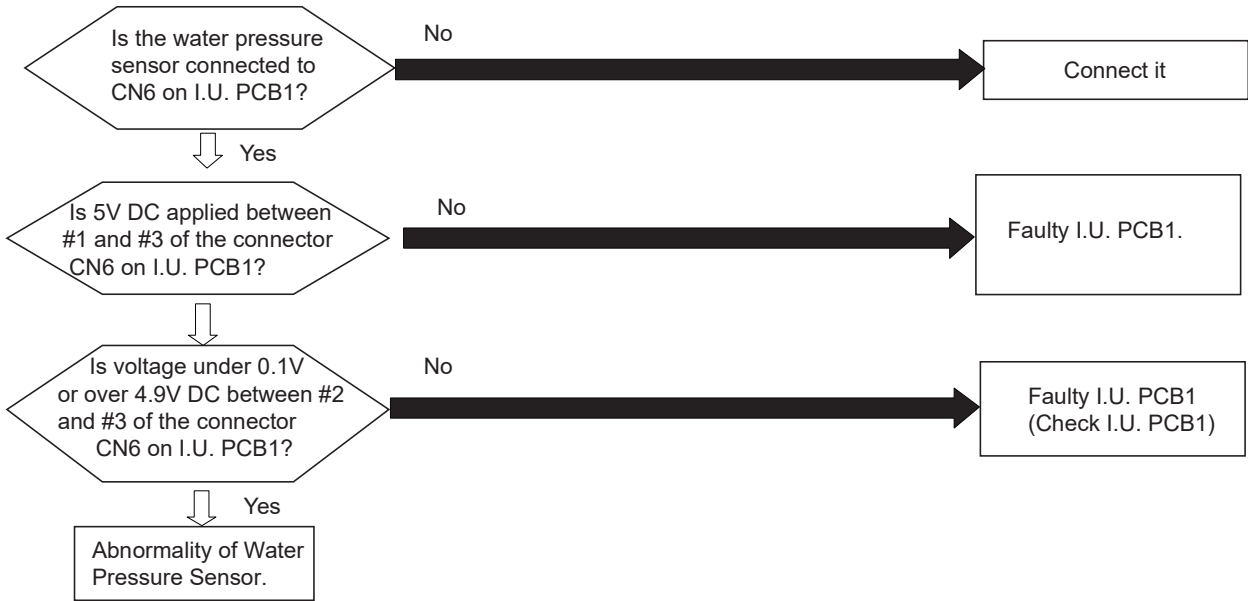

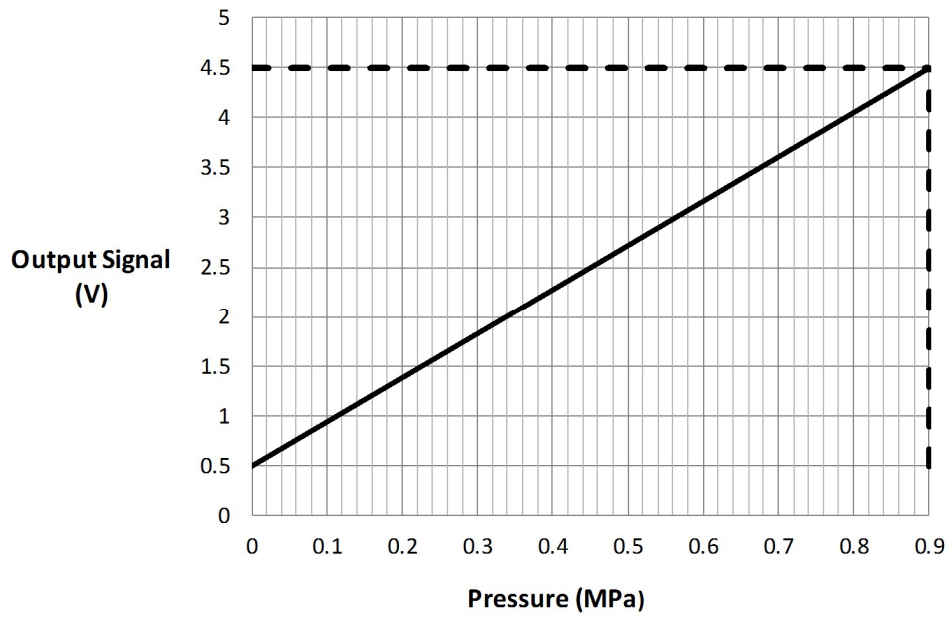

**TRANSFER FUNCTION**

$V_{out}=4.4444 \cdot P_g+0.5$  OR  $V_{out}=V_{in} \cdot (0.8889 \cdot P_g+0.1)$   
 $P_g = \text{MPa (GAUGE)}$

Alarm code	<b>70</b>	Water pressure alarm
------------	-----------	----------------------

- Alarm code is displayed on the master controller/ the 7-segment of O.U. display PCB / the 7-segment of I.U. PCB1.
- This alarm is displayed when there is a low water pressure( $P_w < 0.3\text{bar}$ ) or high water pressure( $P_w \geq 4\text{bar}$ ) abnormality in the hydraulic system for 3 min and the same condition occurs three times or more within 60 minutes.  
Note: The detection is invalid when DSW3-3 ON.
- Reset the unit to release the alarm.

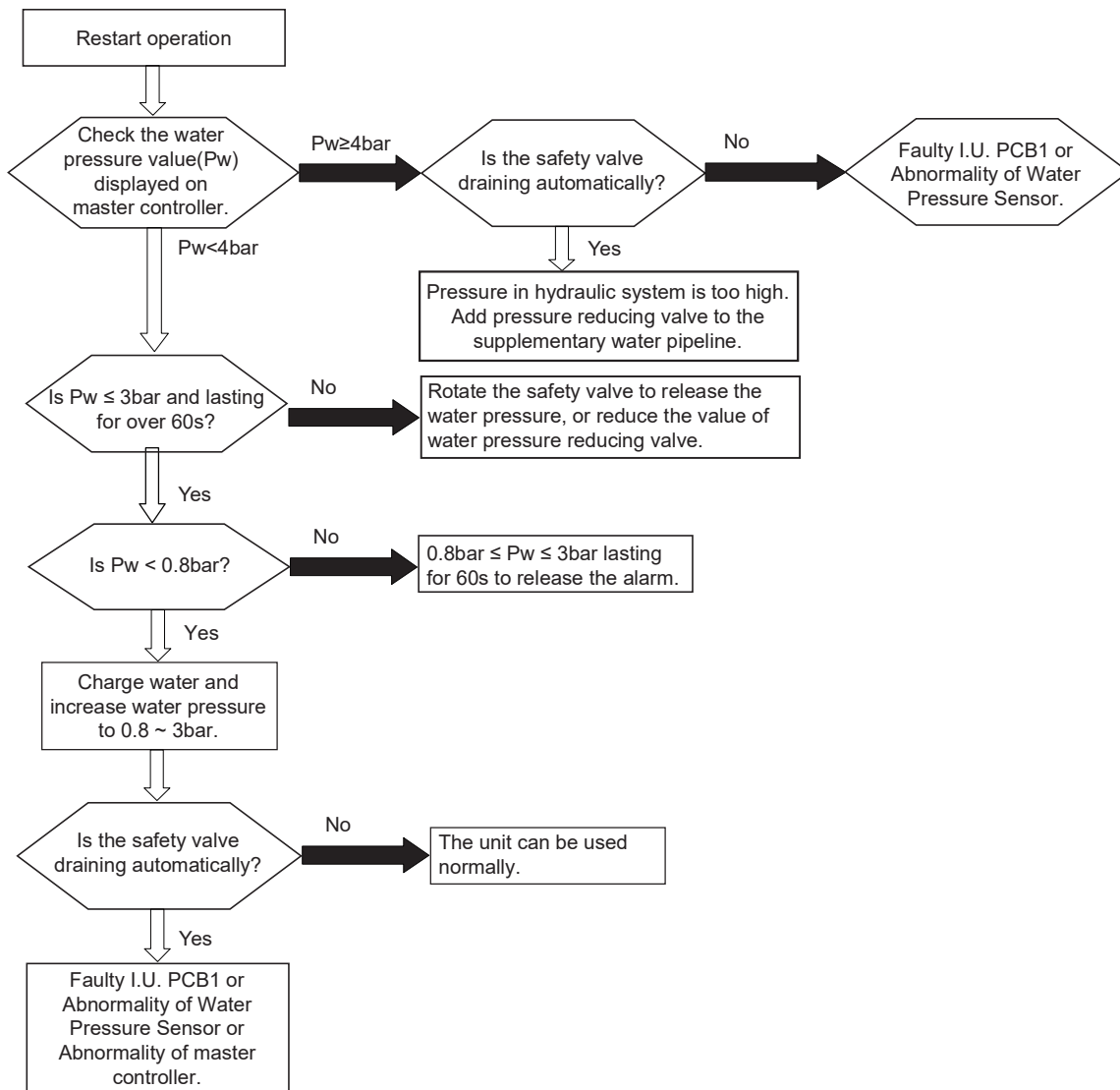



Alarm code	<b>71</b>	Protection Thermostat of DHW Electric Heater activation
------------	-----------	---

- Alarm code is displayed on the master controller/ the 7-segment of O.U. display PCB / the 7-segment of I.U. PCB1.
- This alarm is displayed when the temperature inside the DHW tank exceeds the safety temperature and protection thermostat is activated (field supplied).
- Reset the unit to release the alarm.

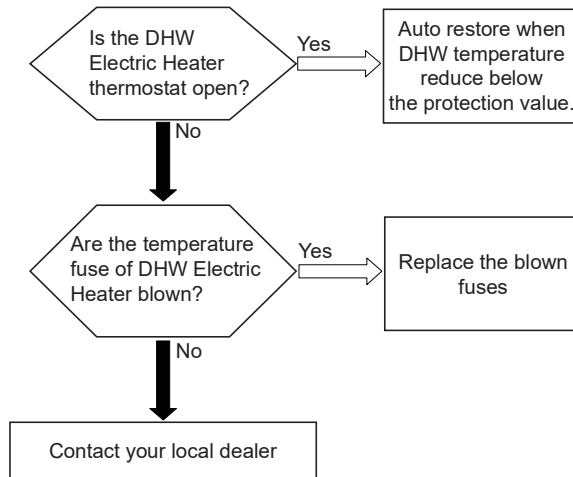

Alarm code	<b>72</b>	Protection Thermostat of Auxiliary Electric Heater Activation
------------	-----------	---

- Alarm code is displayed on the master controller/ the 7-segment of O.U. display PCB / the 7-segment of I.U. PCB1.
- This alarm is displayed when the temperature inside the auxiliary electric heater exceeds the safety temperature and protection thermostat is activated.
- Reset the unit to release the alarm.

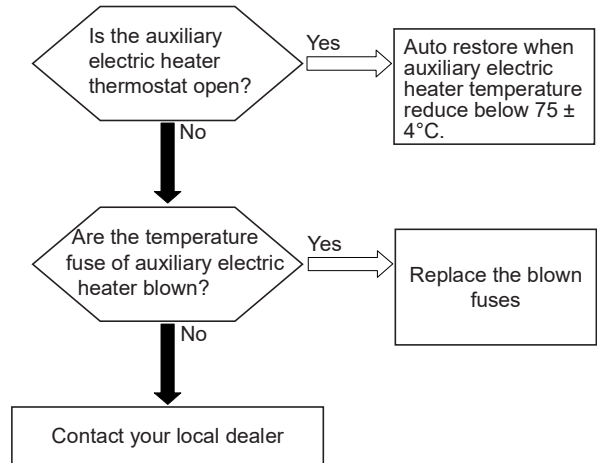

Alarm code	74	Mixing overheating limit protection for mixed circuit (Only if cycle 2 is enabled)
------------	----	--

- Alarm code is displayed on the master controller/ the 7-segment of O.U. display PCB / the 7-segment of I.U. PCB1.
- This alarm code is displayed when outlet water temperature of water cycle 2 (Tow2) is too high as following and the same condition occurs three times or more within 60 minutes.
  - (1) None of [OFF] is set by [Overheat protection offset].
  - (2) Detecting Tow2 is higher than [Max. Water Supply Temp of water cycle 2 + Overheat protection offset] for 10 minutes. referring to 10.2.2.2 Second water temperature control.
- Reset the unit to release the alarm.

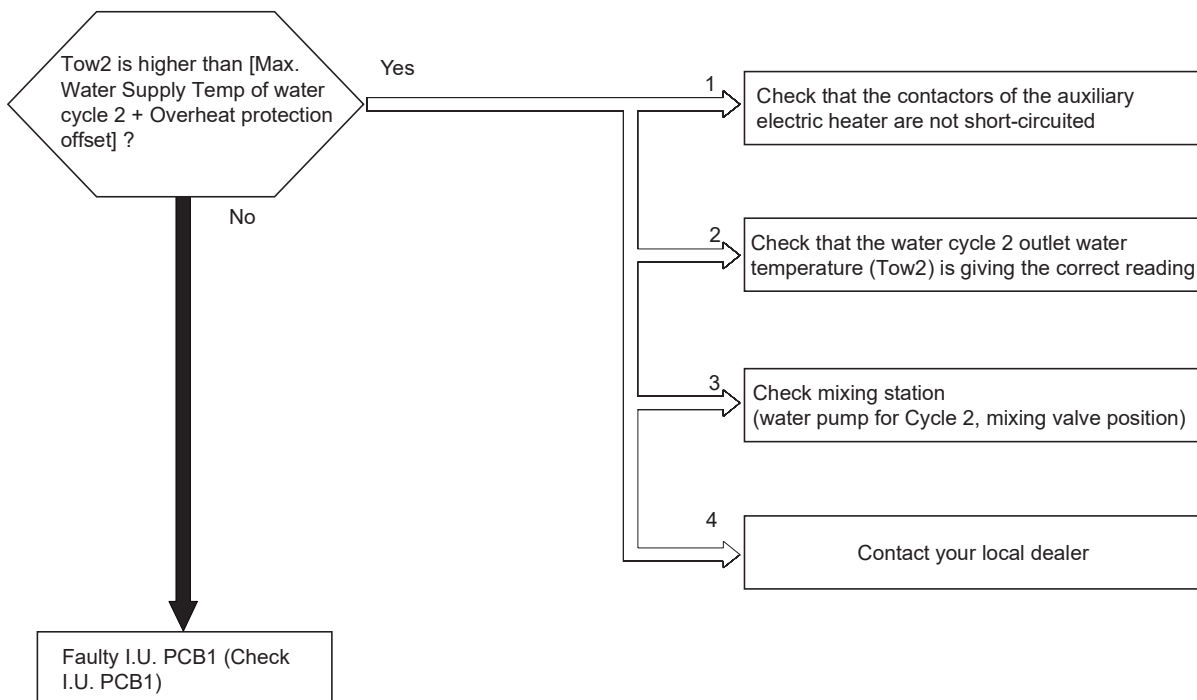

Alarm code	75	Water Pump (WP1) malfunction
------------	----	------------------------------

- Alarm code is displayed on the master controller/ the 7-segment of O.U. display PCB / the 7-segment of I.U. PCB1.
- This alarm is displayed when iPWM output of WP1 are 0 or 80-100% lasting for 120s and the same condition occurs three times or more within 60 minutes. referring to 10.8.4 EC WP1 Water flow feedback.  
Note: The detection is invalid when DSW5-1 ON.
- Reset the unit to release the alarm.

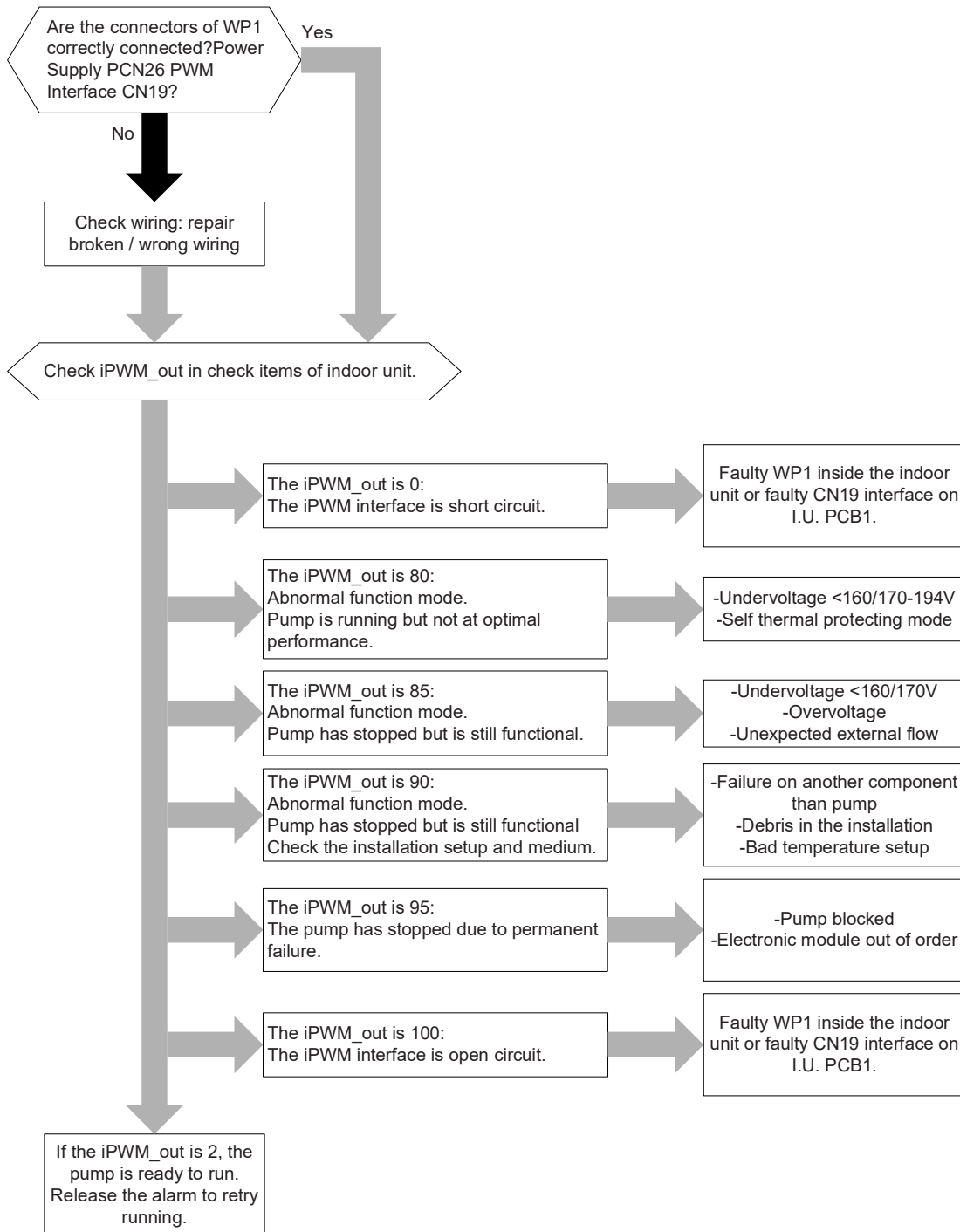

Alarm code	76	Freeze Protection Stop by indoor unit temperature thermistors
------------	----	---

- Alarm code is displayed on the master controller/ the 7-segment of O.U. display PCB / the 7-segment of I.U. PCB1.
- This alarm code is displayed when the following conditions are detected and the same condition occurs three times or more within 3 hours
  - Condition 1:  $TL + TowHP \leq 4[^\circ C]$  and  $TL \leq 1[^\circ C]$  lasting for 180s, during defrosting.
  - Condition 2: Meet any of following conditions during cooling operation:
    - (1)  $TL + TowHP \leq 4[^\circ C]$  and  $TL \leq 1[^\circ C]$  lasting for 180s.
    - (2)  $[TL \leq -4^\circ C]$  and  $[Tg \leq 8^\circ C]$  or  $[Tg \leq 1^\circ C]$  lasting for 240s.
    - (3)  $[TL \leq -16^\circ C]$  and  $[Tg \leq 8^\circ C]$  or  $[Tg \leq -1^\circ C]$  lasting for 60s.
- Reset the unit to release the alarm.

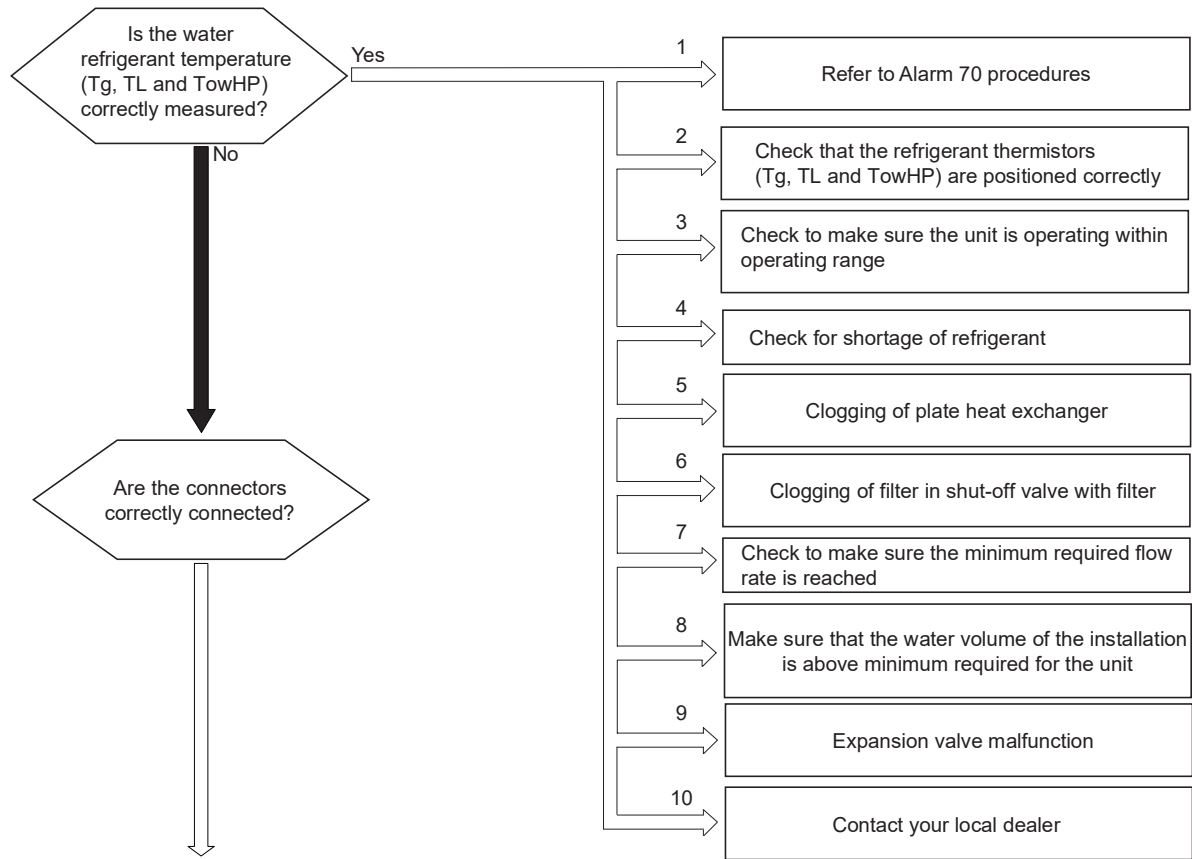

Thermistor	Connector
Tg	THM4
TL	THM5
TowHP	THM3

**No** → Wiring check, repair breaking of wire, wrong wiring

**Yes** → Are thermistors Tg, TL and TowHP correct? (Refer to Alarms 13/14/17 procedures)

**No** → Check Tg, TL and TowHP and replace it

**Yes** → Faulty I.U. PCB1 (Check I.U. PCB1)

→ Contact your local dealer

Alarm code	<b>78</b>	Hydraulic flow rate abnormality alarm (WP1)
------------	-----------	---

- Alarm code is displayed on the master controller/ the 7-segment of O.U. display PCB / the 7-segment of I.U. PCB1.
- This alarm is displayed when there is a low flow rate abnormality in the hydraulic system as following and the same condition occurs three times or more within 60 minutes.  
Note: The detection is invalid when DSW5-1 ON.
- Reset the unit to release the alarm.

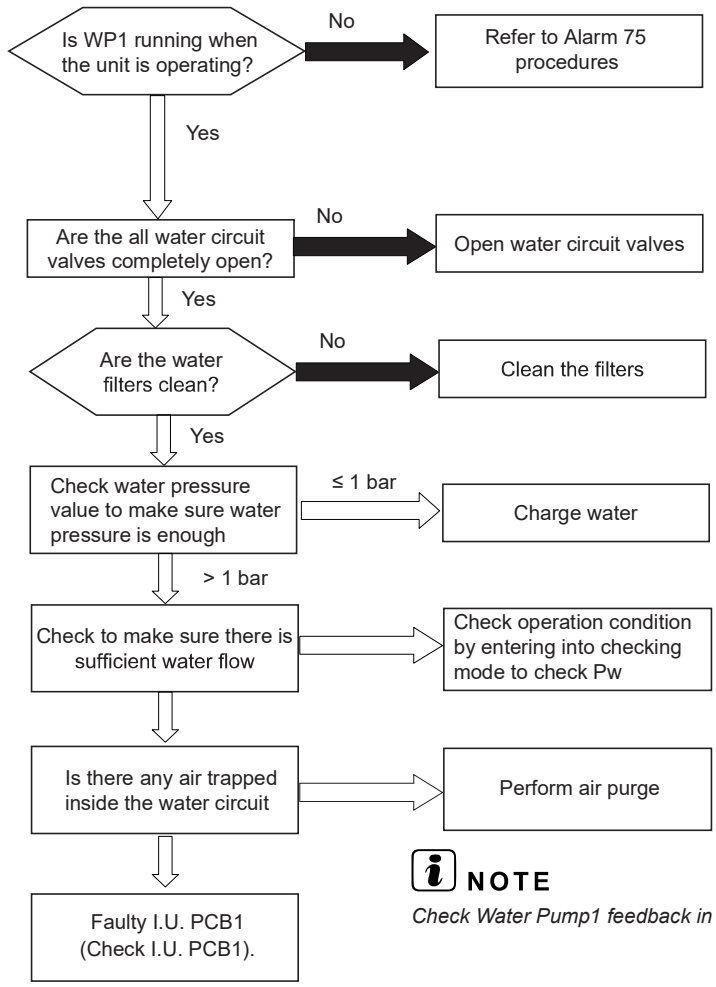

**i NOTE**

Check Water Pump1 feedback in "Alarm Code 75".

Alarm code	80	Transmission failure between Indoor unit and Master Controller
------------	----	--

- Alarm code is displayed on the master controller/ the 7-segment of O.U. display PCB / the 7-segment of I.U. PCB1.
- Alarm code is displayed when there is no communication between indoor unit PCB1 and the Master Controller for 5 minutes.
- Reset the unit to release the alarm.

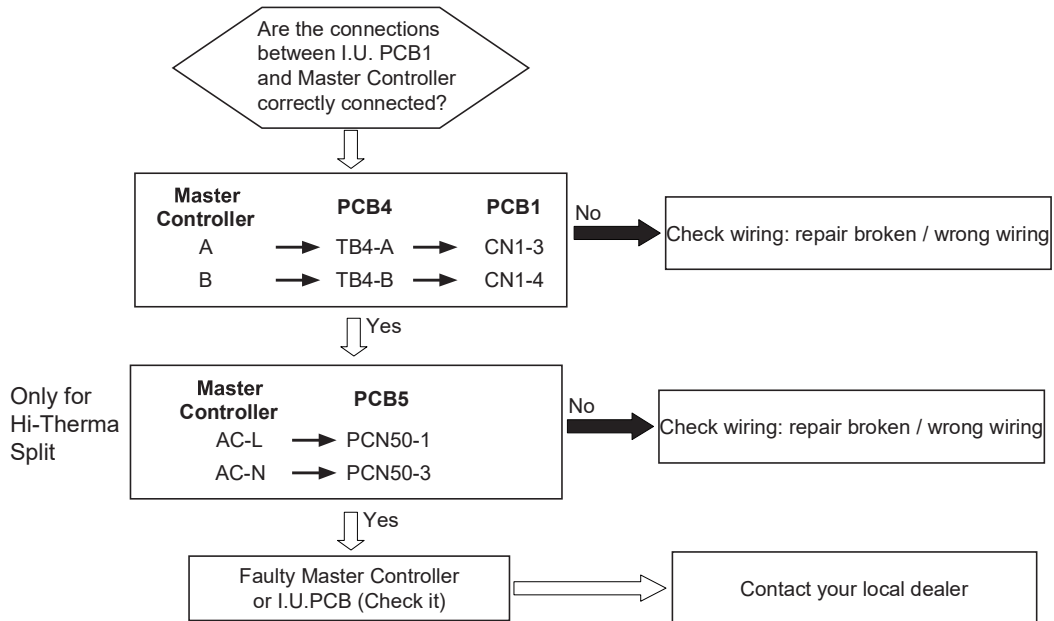

Alarm code	A1	Auxiliary sensor Abnormality (Tow3)
------------	----	-------------------------------------

- Alarm code is displayed on the master controller/ the 7-segment of O.U. display PCB / the 7-segment of I.U. PCB1.
- This alarm code is indicated when a short circuit (less than 0.24kΩ) or disconnection (more than 840kΩ) of the thermistor is detected during the heating or cooling operation. The operation is automatically restarted when the malfunction is removed.
- Reset the unit to release the alarm.

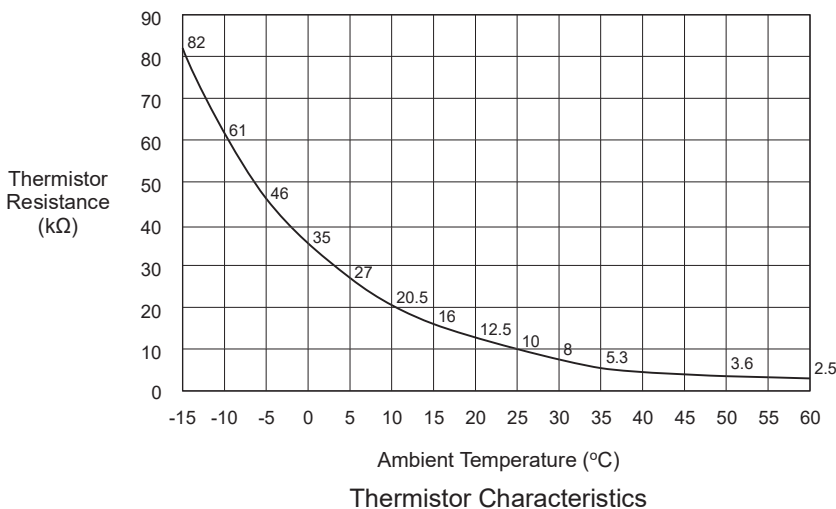
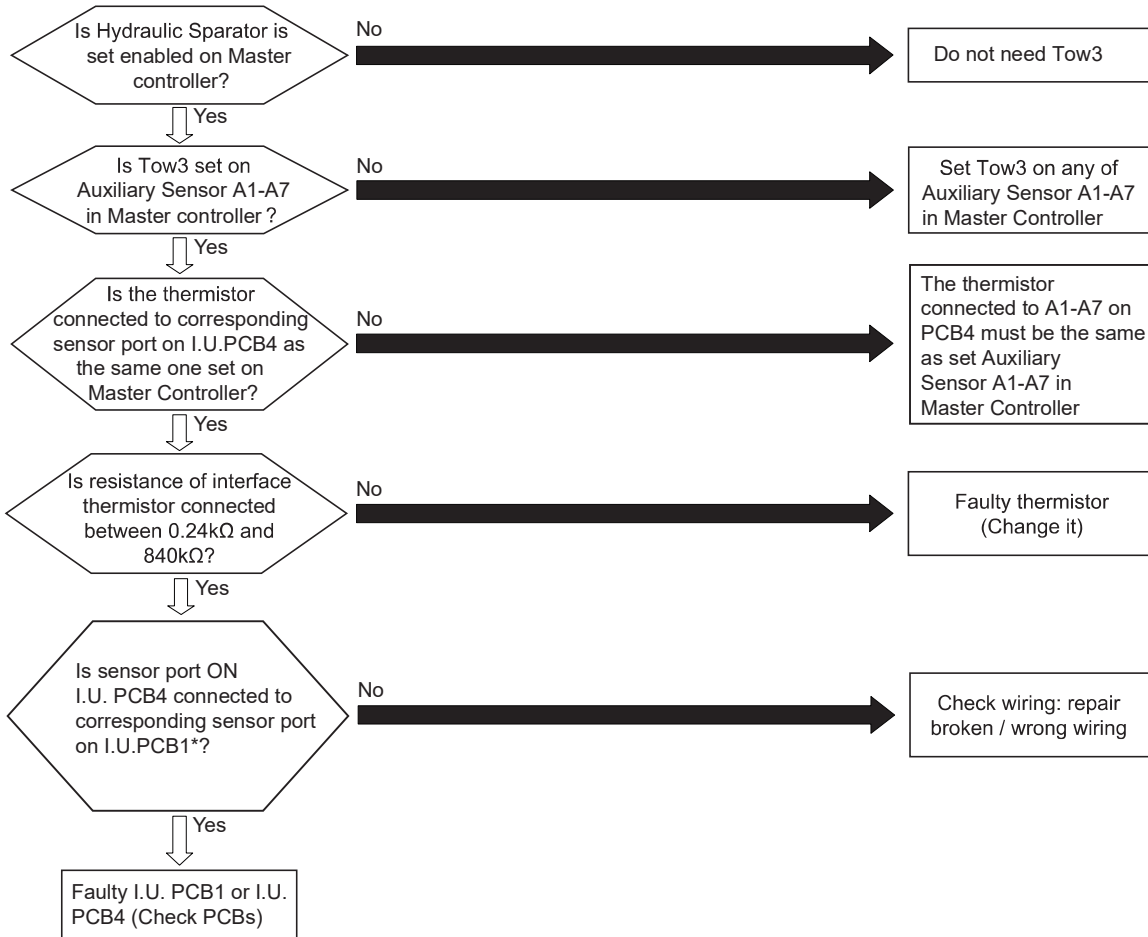

\*I.U. PCB4 connected to corresponding sensor port on I.U.PCB1

I.U. PCN4	I.U.PCN4	I.U.PCB1
A1	CN1-12	THM8
	CN1-11	
A2	CN1-8	THM10
	CN1-7	
A3	CN1-10	THM9
	CN1-9	
A4	CN2-10	THM6
	CN2-9	
A5	CN1-6	THM11
	CN1-5	
A6	CN1-4	THM17
	CN1-3	
A7	CN1-2	THM18
	CN1-1	



Alarm code	<b>A2</b>	Auxiliary sensor Abnormality (Tswp)
------------	-----------	-------------------------------------

- Alarm code is displayed on the master controller/ the 7-segment of O.U. display PCB / the 7-segment of I.U. PCB1.
- This alarm code is indicated when a short circuit (less than 0.24kΩ) or disconnection (more than 840kΩ) of the thermistor is detected during the heating or cooling operation. The operation is automatically restarted when the malfunction is removed.
- Reset the unit to release the alarm.

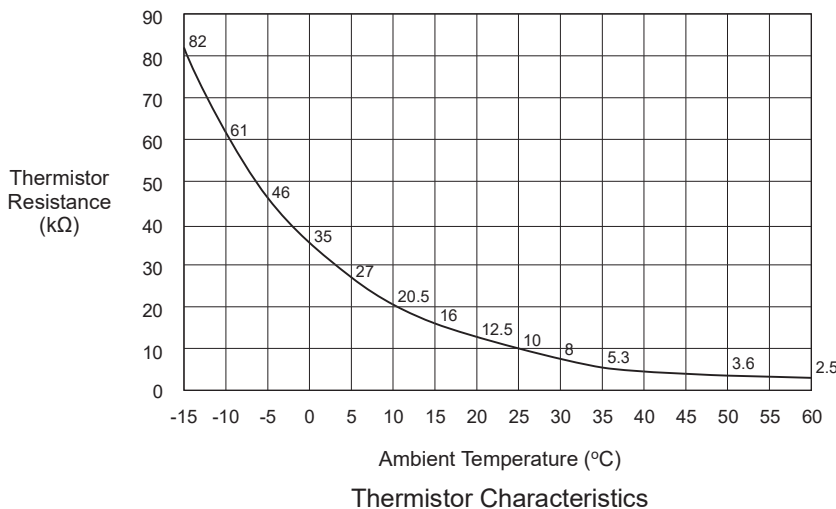
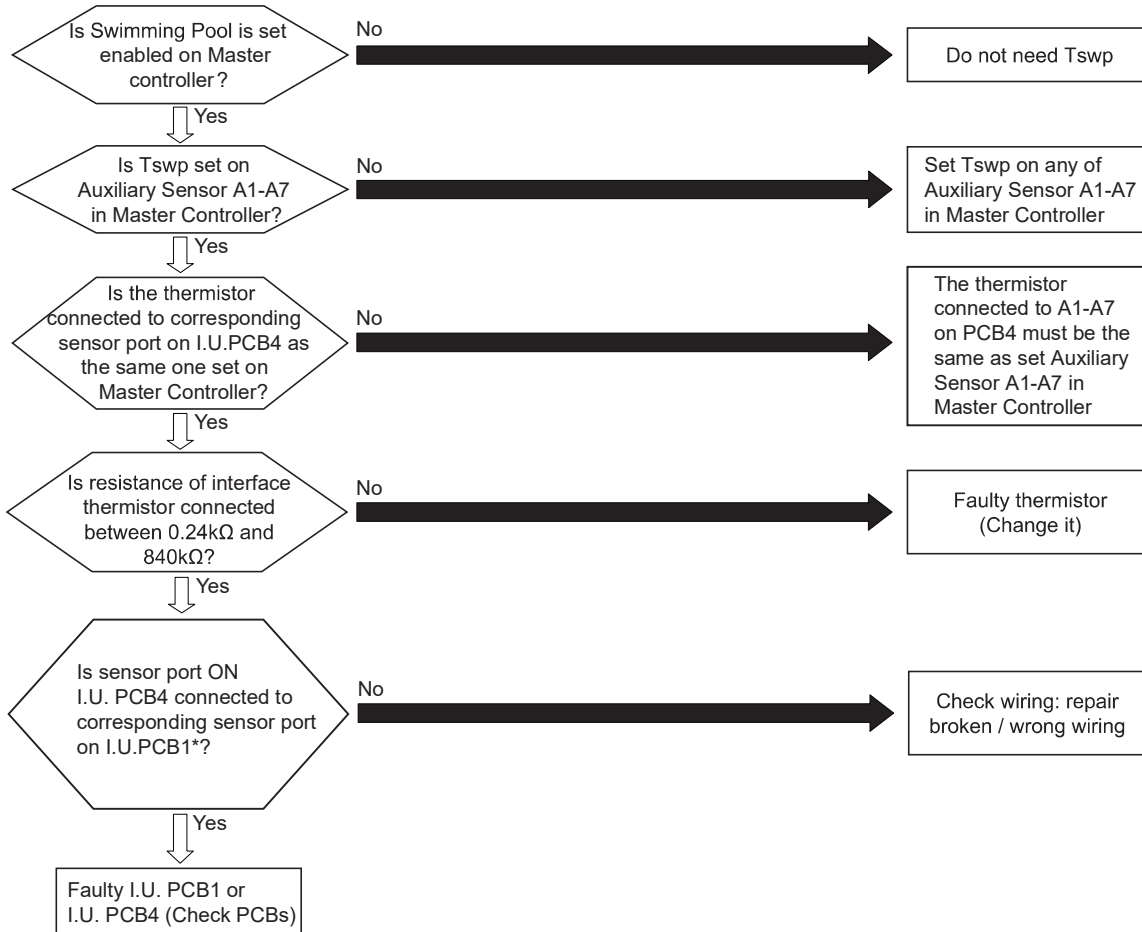

\*I.U. PCB4 connected to corresponding sensor port on I.U.PCB1

I.U. PCN4	I.U.PCN4	I.U.PCB1
A1	CN1-12	THM8
	CN1-11	
A2	CN1-8	THM10
	CN1-7	
A3	CN1-10	THM9
	CN1-9	
A4	CN2-10	THM6
	CN2-9	
A5	CN1-6	THM11
	CN1-5	
A6	CN1-4	THM17
	CN1-3	
A7	CN1-2	THM18
	CN1-1	

Alarm code	<b>A3</b>	Auxiliary sensor Abnormality (Tsolar)
------------	-----------	---------------------------------------

- Alarm code is displayed on the master controller/ the 7-segment of O.U. display PCB / the 7-segment of I.U. PCB1.
- This alarm code is indicated when a short circuit (less than 0.24kΩ) or disconnection (more than 840kΩ) of the thermistor is detected during the heating or cooling operation. The operation is automatically restarted when the malfunction is removed.
- Reset the unit to release the alarm.

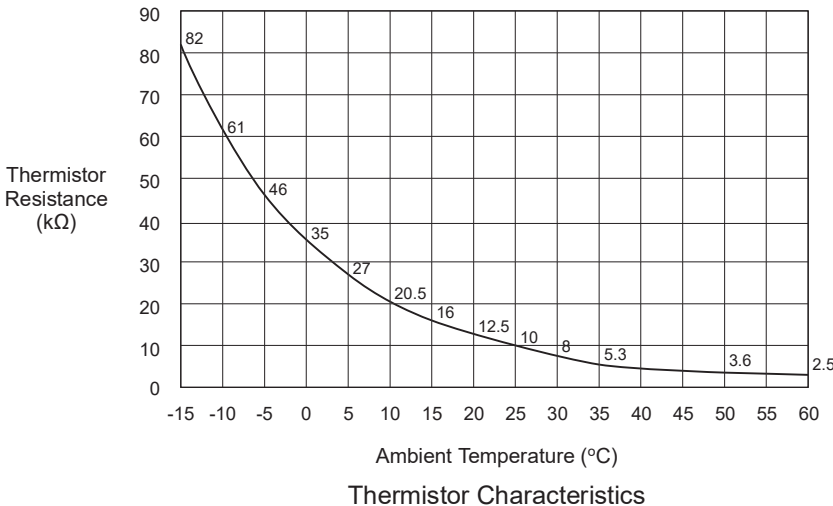
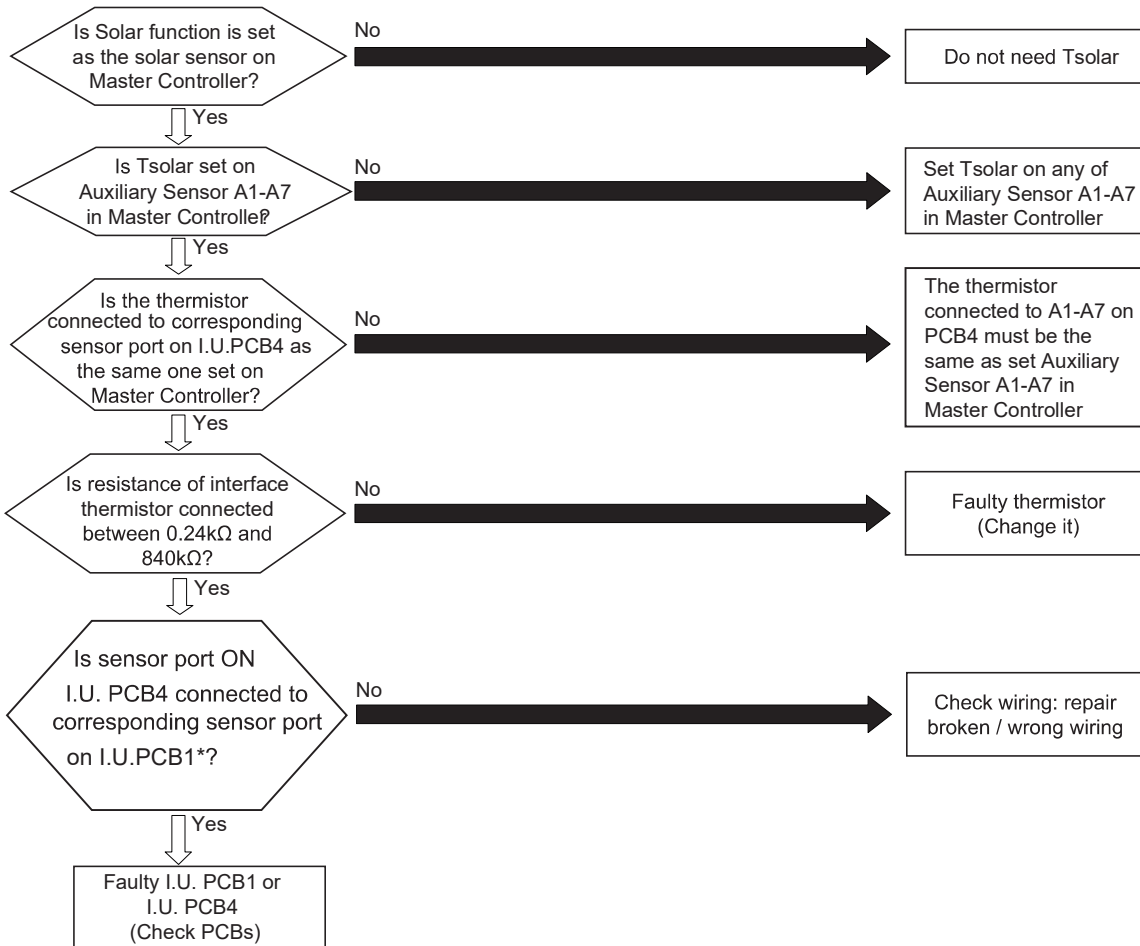

\*I.U. PCB4 connected to corresponding sensor port on I.U.PCB1

I.U. PCN4	I.U.PCN4	I.U.PCB1
A1	CN1-12	THM8
	CN1-11	
A2	CN1-8	THM10
	CN1-7	
A3	CN1-10	THM9
	CN1-9	
A4	CN2-10	THM6
	CN2-9	
A5	CN1-6	THM11
	CN1-5	
A6	CN1-4	THM17
	CN1-3	
A7	CN1-2	THM18
	CN1-1	

Alarm code	A4	Auxiliary sensor Abnormality (Tow2)
------------	----	-------------------------------------

- Alarm code is displayed on the master controller/ the 7-segment of O.U. display PCB / the 7-segment of I.U. PCB1.
- This alarm code is indicated when a short circuit (less than 0.24kΩ) or disconnection (more than 840kΩ) of the thermistor is detected during the heating or cooling operation. The operation is automatically restarted when the malfunction is removed.
- Reset the unit to release the alarm.

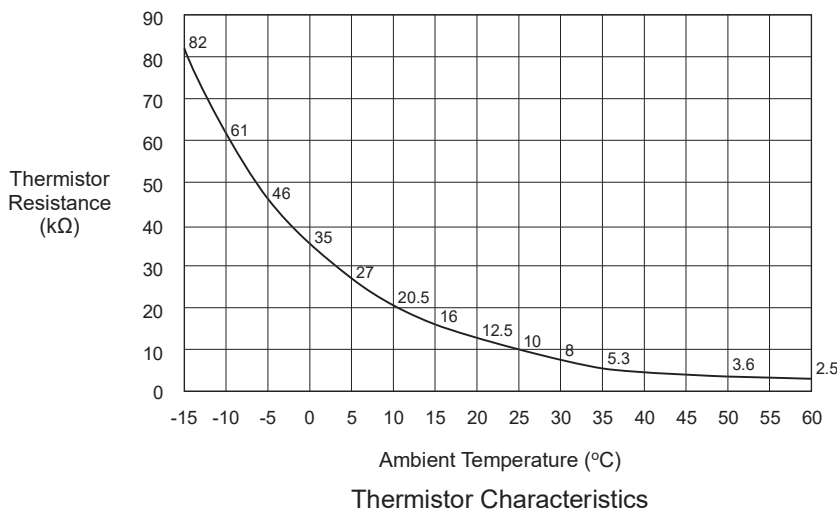
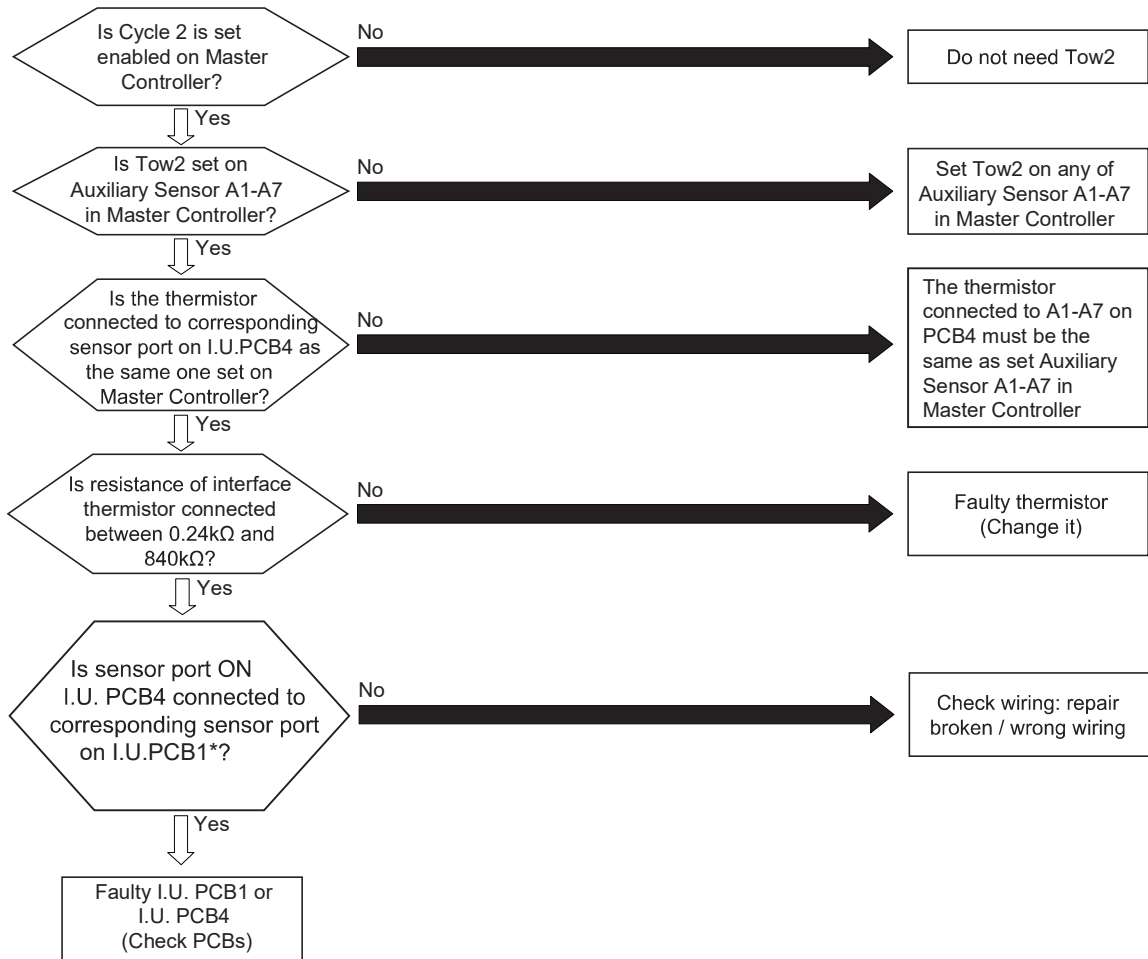

\*I.U. PCB4 connected to corresponding sensor port on I.U.PCB1

I.U. PCN4	I.U.PCN4	I.U.PCB1
A1	CN1-12	THM8
	CN1-11	
A2	CN1-8	THM10
	CN1-7	
A3	CN1-10	THM9
	CN1-9	
A4	CN2-10	THM6
	CN2-9	
A5	CN1-6	THM11
	CN1-5	
A6	CN1-4	THM17
	CN1-3	
A7	CN1-2	THM18
	CN1-1	

Alarm code	<b>A5</b>	Auxiliary sensor Abnormality (Room_amb1...7)
------------	-----------	--

- Alarm code is displayed on the master controller/ the 7-segment of O.U. display PCB / the 7-segment of I.U. PCB1.
- This alarm code is indicated when a short circuit (less than 0.24kΩ) or disconnection (more than 840kΩ) of the thermistor is detected during the heating or cooling operation. The operation is automatically restarted when the malfunction is removed.
- Reset the unit to release the alarm.

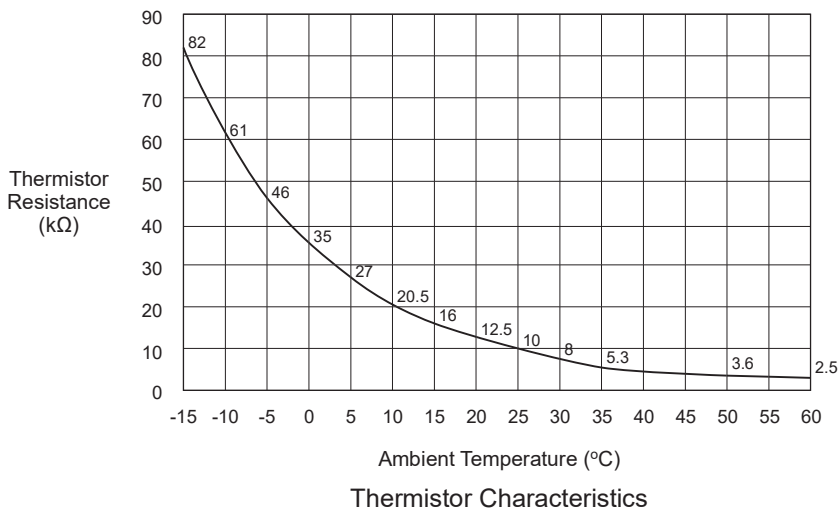
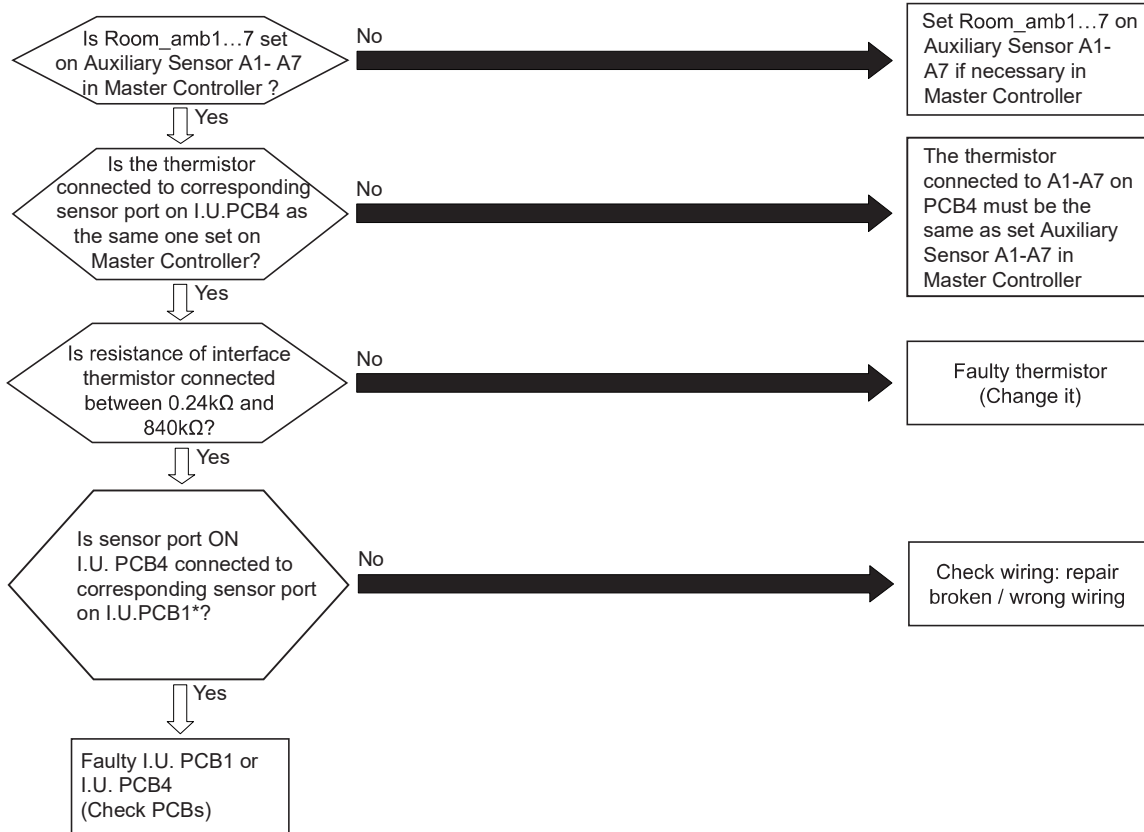

\*I.U. PCB4 connected to corresponding sensor port on I.U.PCB1

I.U. PCN4	I.U.PCN4	I.U.PCB1
A1	CN1-12	THM8
	CN1-11	
A2	CN1-8	THM10
	CN1-7	
A3	CN1-10	THM9
	CN1-9	
A4	CN2-10	THM6
	CN2-9	
A5	CN1-6	THM11
	CN1-5	
A6	CN1-4	THM17
	CN1-3	
A7	CN1-2	THM18
	CN1-1	

Alarm code	<b>F1</b>	Alarm sent by Outdoor unit (Outdoor unit alarm 21-29).
------------	-----------	--

- Alarm code is displayed on the master controller / the 7-segment of I.U. PCB1.
- Reset the unit to release the alarm.

Alarm code	<b>F2</b>	Alarm sent by Outdoor unit (Outdoor unit alarm except 21-29 and EE).
------------	-----------	--

- Alarm code is displayed on the master controller / the 7-segment of I.U. PCB1.
- Reset the unit to release the alarm.

Alarm code	<b>F3</b>	Alarm sent by Outdoor unit (Outdoor unit alarm EE).
------------	-----------	---

- Alarm code is displayed on the master controller / the 7-segment of I.U. PCB1.
- Reset the unit to release the alarm.

Alarm code	<b>H2</b>	Wired Remote Controller and Master Controller transmission alarm.
------------	-----------	---

- This alarm is displayed only on Master Controller.
- Wired Remote Controller is configured as room thermostat but no Wired Remote Controller is detected.
- Reset the unit to release the alarm.



**Hisense**



EXCLUSIEF IMPORTEUR VAN HISENSE BENELUX

Carneool 400  
3316 KC Dordrecht  
Nederland

Tel.: +31 (0) 88 4 35 54 50  
E-Mail: [info@hs-cs.nl](mailto:info@hs-cs.nl)

Truibroek 94 | unit 11  
3945 Ham  
België

Tel.: +32 (0) 11 46 04 46  
E-Mail: [info@hs-cs.be](mailto:info@hs-cs.be)